

**ANNEX 5**

**RESOLUTION MEPC.332(76)  
(adopted on 17 June 2021)**

**AMENDMENTS TO THE 2018 GUIDELINES ON THE METHOD OF CALCULATION OF  
THE ATTAINED ENERGY EFFICIENCY DESIGN INDEX (EEDI) FOR NEW SHIPS  
(RESOLUTION MEPC.308(73), AS AMENDED BY RESOLUTION MEPC.322(74))**

THE MARINE ENVIRONMENT PROTECTION COMMITTEE,

RECALLING article 38(a) of the Convention on the International Maritime Organization concerning the functions of the Marine Environment Protection Committee (the Committee) conferred upon it by international conventions for the prevention and control of marine pollution from ships,

RECALLING ALSO that, at its sixty-second session, it adopted, by resolution MEPC.203(62), *Amendments to the annex of the Protocol of 1997 to amend the International Convention for the Prevention of Pollution from Ships, 1973, as modified by the Protocol of 1978 relating thereto* (inclusion of regulations on energy efficiency for ships in MARPOL Annex VI),

NOTING that the aforementioned amendments to MARPOL Annex VI entered into force on 1 January 2013,

NOTING ALSO that regulation 22 (Attained Energy Efficiency Design Index (attained EEDI)) of MARPOL Annex VI, as amended, requires that the EEDI shall be calculated taking into account the guidelines developed by the Organization,

NOTING FURTHER the *2012 Guidelines on the method of calculation of the attained Energy Efficiency Design Index (EEDI) for new ships*, adopted at its sixty-third session by resolution MEPC.212(63), superseded by the *2014 Guidelines on the method of calculation of the attained Energy Efficiency Design Index (EEDI) for new ships* (resolution MEPC.245(66)), which were subsequently superseded by the *2018 Guidelines on the method of calculation of the attained Energy Efficiency Design Index (EEDI) for new ships* (resolution MEPC.308(73)),

NOTING that, at its seventy-fourth session, it adopted, by resolution MEPC.322(74), *Amendments to the 2018 Guidelines on the method of calculation of the attained Energy Efficiency Design Index (EEDI) for new ships*,

HAVING CONSIDERED, at its seventy-sixth session, proposed amendments to the *2018 Guidelines on the method of calculation of the attained Energy Efficiency Design Index (EEDI) for new ships* (resolution MEPC.308(73), as amended by resolution MEPC.322(74)),

1 ADOPTS amendments to the *2018 Guidelines on the method of calculation of the attained Energy Efficiency Design Index (EEDI) for new ships* (resolution MEPC.308(73), as amended by resolution MEPC.322(74)), as set out in the annex to the present resolution;

2 INVITES Administrations to take into account the aforementioned amendments when developing and enacting national laws which give force to, and implement provisions set forth in regulation 20 of MARPOL Annex VI, as amended;

3 REQUESTS the Parties to MARPOL Annex VI and other Member Governments to bring the amendments to the attention of shipowners, ship operators, shipbuilders, ship designers and any other interested parties;

4 AGREES to keep these Guidelines, as amended, under review, in light of experience gained with their implementation.

ANNEX

**AMENDMENTS TO THE 2018 GUIDELINES ON THE METHOD OF CALCULATION OF  
THE ATTAINED ENERGY EFFICIENCY DESIGN INDEX (EEDI) FOR NEW SHIPS**

1 A new section 3 is added, as follows:

**"3 Mandatory Reporting of Attained EEDI Values and Related Information**

3.1 In accordance with regulation 22.3 of MARPOL Annex VI, for each ship subject to regulation 24, the Administration or any organization duly authorized by it shall report the required and attained EEDI values and relevant information taking into account these Guidelines via electronic communication.

3.2 Information to be reported are as follows:

- .1 applicable EEDI phase (e.g. Phase 1, Phase 2, etc.);
- .2 identification number (IMO Secretariat use only);
- .3 ship type;
- .4 common commercial size reference\* (see Note (3) in appendix 5 to these Guidelines), if available;
- .5 DWT or GT (as appropriate);
- .6 year of delivery;
- .7 required EEDI value;
- .8 attained EEDI value;
- .9 dimensional parameters (length  $L_{pp}$  (m), breadth  $B_s$  (m), and draught (m));
- .10  $V_{ref}$  (knots) and  $P_{ME}$  (kW);
- .11 use of innovative technologies (4th and 5th terms in the EEDI equation, if applicable);
- .12 short statement\* describing the principal design elements or changes employed to achieve the attained EEDI (as appropriate), if available;
- .13 type of fuel used in the calculation of the attained EEDI, and for dual-fuel engines, the  $f_{DFgas}$  ratio; and
- .14 ice class designation (if applicable).

---

\* Not subject to verification.

- 3.3 The information in paragraph 3.2 is not required to be reported for ships for which the required and attained EEDI values had been already reported to the Organization.
  - 3.4 A standardized reporting format for Mandatory Reporting of Attained EEDI Values and Related Information is presented in appendix 5."
- 2 A new appendix 5 is added, as follows:

"APPENDIX 5

**STANDARD FORMAT TO SUBMIT EEDI INFORMATION TO BE INCLUDED IN THE EEDI DATABASE**

IMO Number (1)	Type of ship (2)	Common commercial size (3)	Capacity (4)		Dimensional parameters			Year of delivery	Applicable phase	Required EEDI	Attained EEDI	Vref (knot) (9)	PME (kW) (10)	Type of fuel (11)	f <sub>DF</sub> gas (12)	Ice class (13)	EEDI 4th term (Installation of innovative electrical technology)		EEDI 5th term (Installation of innovative mechanical technology)		Short statement as appropriate describing the principal design elements or changes employed to achieve the attained EEDI (15)	
			DWT	GT (5)	Lpp (m) (6)	Bs (m) (7)	Draught (m) (8)										Yes/No	Name, outline and means/ways of performance of technology (14)	Yes/No	Name, outline and means/ways of performance of technology (14)		

- Note:**
- (1) IMO number to be submitted for Secretariat use only.
  - (2) As defined in regulation 2 of MARPOL Annex VI.
  - (3) Common commercial size reference (TEU for containership, CEU (RT43) for ro-ro cargo ship (vehicle carrier), cubic meter for gas carrier and LNG carrier), if available, should be provided.
  - (4) The exact DWT or GT, as appropriate, should be provided. The Secretariat should round the DWT or GT data up to the nearest 500 when these data are subsequently provided to MEPC. (For containerships, 100% DWT should be provided while 70% of DWT should be used when calculating the EEDI value).
  - (5) GT should be provided for a cruise passenger ship having non-conventional propulsion as defined in regulations 2.2.11 and 2.2.19, respectively, of MARPOL Annex VI. Both DWT and GT should be provided for a ro-ro cargo ship (vehicle carrier) as defined in regulation 2.2.27 of MARPOL Annex VI.
  - (6) As defined in paragraph 2.2.13 of the *2018 Guidelines on the method of calculation of the attained Energy Efficiency Design Index (EEDI) for new ships* (resolution MEPC.308(73), as amended). The exact Lpp should be provided. The Secretariat will round the Lpp data up to the nearest 10 when these data are subsequently provided to MEPC.
  - (7) As defined in paragraph 2.2.16 of the *2018 Guidelines on the method of calculation of the attained Energy Efficiency Design Index (EEDI) for new ships* (resolution MEPC.308(73), as amended). The exact Bs should be provided. The Secretariat will round the Bs data up to the nearest 1 when these data are subsequently provided to MEPC.
  - (8) As defined in paragraph 2.2.15 of the *2018 Guidelines on the method of calculation of the attained Energy Efficiency Design Index (EEDI) for new ships* (resolution MEPC.308(73), as amended). The exact draught should be provided. The Secretariat will round the draught data up to the nearest 1 when these data are subsequently provided to MEPC.
  - (9) As defined in paragraph 2.2.2 of the *2018 Guidelines on the method of calculation of the attained Energy Efficiency Design Index (EEDI) for new ships* (resolution MEPC.308(73), as amended). The exact Vref should be provided. The Secretariat will round the Vref data up to the nearest 0.5 when these data are subsequently provided to MEPC.
  - (10) As defined in paragraph 2.2.5.1 of the *2018 Guidelines on the method of calculation of the attained Energy Efficiency Design Index (EEDI) for new ships* (resolution MEPC.308(73), as amended). The exact P<sub>ME</sub> should be provided. The Secretariat will round the P<sub>ME</sub> data up to the nearest 100 when these data are subsequently provided to MEPC.
  - (11) As defined in paragraph 2.2.1 of the *2018 Guidelines on the method of calculation of the attained Energy Efficiency Design Index (EEDI) for new ships* (resolution MEPC.308(73), as amended) or other (to be stated). In case of a ship equipped with a dual-fuel engine, type of "primary fuel" should be provided.
  - (12) As defined in paragraph 2.2.1 of the *2018 Guidelines on the method of calculation of the attained Energy Efficiency Design Index (EEDI) for new ships* (resolution MEPC.308 (73), as amended), if applicable.
  - (13) Ice class, which was used to calculate correction factors for ice-classed ships as defined in paragraphs 2.2.8.1 and 2.2.11.1 of the *2018 Guidelines on the method of calculation of the attained Energy Efficiency Design Index (EEDI) for new ships* (resolution MEPC.308(73), as amended), if applicable, should be provided.
  - (14) In the case that the innovative energy efficiency technologies are already included in the *2013 Guidance on treatment of innovative energy efficiency technologies for calculation and verification of the attained EEDI* (MEPC.1/Circ.815), the name of technology should be identified. Otherwise, name, outline and means/ways of performance of the technology should be identified.
  - (15) To assist the IMO in assessing relevant design trends, provide a short statement as appropriate, describing the principal design elements or changes employed to achieve the attained EEDI.

\*\*\*



---

**ANNEX 6**

**UNIFIED INTERPRETATION TO REGULATION 2.23 OF MARPOL ANNEX VI**

(update to the unified interpretation provided in paragraphs 1.2.3 and 1.2.4 of the annex to MEPC.1/Circ.795/Rev.4)

**1 Definition of "new ship"**

Regulation 2  
*Definitions*

Regulation 2.23 reads as follows:

"*New ship* means a ship:

- .1 for which the building contract is placed on or after 1 January 2013; or
- .2 in the absence of a building contract, the keel of which is laid or which is at a similar stage of construction on or after 1 July 2013; or
- .3 the delivery of which is on or after 1 July 2015."

***Interpretation:***

1.1 For the application of the definition "new ship" as specified in regulation 2.23 to each phase specified in table 1 of regulation 21, it should be interpreted as follows:

- .1 the date specified in regulation 2.23.1 should be replaced with the start date of each phase;
- .2 the date specified in regulation 2.23.2 should be replaced with the date six months after the start date of each phase; and
- .3 the date specified in regulation 2.23.3 should, for Phase 1, 2 and 3, be replaced with the date 48 months after the start date of each phase.

1.2 With the above interpretations, the required EEDI of each phase is applied to the following new ship which falls into one of the categories defined in regulations 2.25 to 2.31 and to which chapter 4 is applicable:

(.....)

- .3 the required EEDI of Phase 2 is applied to the following new ship:
  - .1 for ship types where Phase 2 ends on 31 March 2022\*:
    - .1 the building contract of which is placed in Phase 2, and the delivery is before 1 April 2026; or

---

\* Unified Interpretation is applicable when resolution MEPC.324(75) enters into force on 1 April 2022.

.2 the building contract of which is placed before Phase 2, and the delivery is on or after 1 January 2024 and before 1 April 2026; or

in the absence of a building contract:

.3 the keel of which is laid or which is at a similar stage of construction on or after 1 July 2020 and before 1 October 2022, and the delivery is before 1 April 2026; or

.4 the keel of which is laid or which is at a similar stage of construction before 1 July 2020, and the delivery is on or after 1 January 2024 and before 1 April 2026.

.2 for ship types where Phase 2 ends on 31 December 2024:

.1 the building contract of which is placed in Phase 2, and the delivery is before 1 January 2029; or

.2 the building contract of which is placed before Phase 2, and the delivery is on or after 1 January 2024 and before 1 January 2029; or

in the absence of a building contract:

.3 the keel of which is laid or which is at a similar stage of construction on or after 1 July 2020 and before 1 July 2025, and the delivery is before 1 January 2029; or

.4 the keel of which is laid or which is at a similar stage of construction before 1 July 2020, and the delivery is on or after 1 January 2024 and before 1 January 2029.

.4 the required EEDI of Phase 3 is applied to the following new ship:

.1 for ship types where Phase 3 commences with 1 April 2022 and onwards:

.1 the building contract of which is placed in Phase 3; or

.2 the building contract of which is placed before Phase 3, and the delivery is on or after 1 April 2026; or

in the absence of a building contract:

.3 the keel of which is laid or which is at a similar stage of construction on or after 1 October 2022; or

.4 the keel of which is laid or which is at a similar stage of construction before 1 October 2022 and the delivery of which is on or after 1 April 2026.

.2 for ship types where Phase 3 commences with 1 January 2025 and onwards:



- .1 the building contract of which is placed in Phase 3; or
- .2 the building contract of which is placed before Phase 3, and the delivery is on or after 1 January 2029; or

in the absence of a building contract:

- .3 the keel of which is laid or which is at a similar stage of construction on or after 1 July 2025; or
- .4 the keel of which is laid or which is at a similar stage of construction before 1 July 2025 and the delivery of which is on or after 1 January 2029.

(.....)

\*\*\*



**ANNEX 7**

**RESOLUTION MEPC.333(76)  
(adopted on 17 June 2021)**

**2021 GUIDELINES ON THE METHOD OF CALCULATION OF THE ATTAINED  
ENERGY EFFICIENCY EXISTING SHIP INDEX (EEXI)**

THE MARINE ENVIRONMENT PROTECTION COMMITTEE,

RECALLING Article 38(a) of the Convention on the International Maritime Organization concerning the functions of the Marine Environment Protection Committee conferred upon it by international conventions for the prevention and control of marine pollution from ships,

NOTING that it adopted, by resolution MEPC.328(76), the 2021 revised MARPOL Annex VI, which is expected to enter into force on 1 November 2022 upon its deemed acceptance on 1 May 2022,

NOTING IN PARTICULAR that the 2021 revised MARPOL Annex VI contains amendments concerning mandatory goal-based technical and operational measures to reduce carbon intensity of international shipping,

NOTING FURTHER that regulation 23 of MARPOL Annex VI requires that the attained EEXI shall be calculated taking into account the guidelines developed by the Organization,

RECOGNIZING that the aforementioned amendments to MARPOL Annex VI require relevant guidelines for uniform and effective implementation of the regulations and to provide sufficient lead time for industry to prepare,

HAVING CONSIDERED, at its seventy-sixth session, draft *2021 Guidelines on the method of calculation of the attained Energy Efficiency Existing Ship Index (EEXI)*,

1 ADOPTS the *2021 Guidelines on the method of calculation of the attained Energy Efficiency Existing Ship Index (EEXI)*, as set out in the annex to the present resolution;

2 INVITES Administrations to take the annexed Guidelines into account when developing and enacting national laws which give force to and implement requirements set forth in regulation 23 of MARPOL Annex VI;

3 REQUESTS the Parties to MARPOL Annex VI and other Member Governments to bring the annexed Guidelines to the attention of masters, seafarers, shipowners, ship operators and any other interested parties;

4 AGREES to keep the Guidelines under review in light of experience gained with their implementation and in light of the review of EEXI regulations to be completed by the Organization by 1 January 2026 as identified in regulation 25.3 of MARPOL Annex VI.

## ANNEX

### 2021 GUIDELINES ON THE METHOD OF CALCULATION OF THE ATTAINED ENERGY EFFICIENCY EXISTING SHIP INDEX (EEXI)

#### CONTENTS

- 1 Definitions
- 2 Energy Efficiency Existing Ship Index (EEXI)
  - 2.1 EEXI formula
  - 2.2 Parameters
    - 2.2.1  $P_{ME(i)}$ ; Power of main engines
    - 2.2.2  $P_{AE(i)}$ ; Power of auxiliary engines
    - 2.2.3  $V_{ref}$ ; Ship speed
    - 2.2.4  $SFC$ ; Certified specific fuel consumption
    - 2.2.5  $C_F$ ; Conversion factor between fuel consumption and CO<sub>2</sub> emission
    - 2.2.6 Correction factor for ro-ro cargo and ro-ro passenger ships ( $f_{jRoRo}$ )
    - 2.2.7 Correction factor for ro-ro cargo ships (vehicle carrier) ( $f_{cVEHICLE}$ )
- APPENDIX Parameters to calculate  $V_{ref,app}$

## 1 Definitions

1.1 *MARPOL* means the International Convention for the Prevention of Pollution from Ships, 1973, as modified by the Protocols of 1978 and 1997 relating thereto, as amended.

1.2 For the purpose of these Guidelines, the definitions in MARPOL Annex VI, as amended, apply.

## 2 Energy Efficiency Existing Ship Index (EEXI)

### 2.1 EEXI formula

The attained Energy Efficiency Existing Ship Index (EEXI) is a measure of ship's energy efficiency (g/t\*nm) and calculated by the following formula:

$$\frac{\left( \prod_{j=1}^n f_j \right) \left( \sum_{i=1}^{nME} P_{ME(i)} \cdot C_{FME(i)} \cdot SFC_{ME(i)} \right) + (P_{AE} \cdot C_{FAE} \cdot SFC_{AE}^*) + \left( \left( \prod_{j=1}^n f_j \cdot \sum_{i=1}^{nPTI} P_{PTI(i)} - \sum_{i=1}^{neff} f_{eff(i)} \cdot P_{AEff(i)} \right) C_{FAE} \cdot SFC_{AE} \right) - \left( \sum_{i=1}^{neff} f_{eff(i)} \cdot P_{eff(i)} \cdot C_{FME} \cdot SFC_{ME}^{**} \right)}{f_i \cdot f_c \cdot f_i \cdot Capacity \cdot f_w \cdot V_{ref} \cdot f_m}$$

\* If part of the Normal Maximum Sea Load is provided by shaft generators,  $SFC_{ME}$  and  $C_{FME}$  may – for that part of the power – be used instead of  $SFC_{AE}$  and  $C_{FAE}$

\*\* In case of  $P_{PTI(i)} > 0$ , the average weighted value of  $(SFC_{ME} \cdot C_{FME})$  and  $(SFC_{AE} \cdot C_{FAE})$  to be used for calculation of  $P_{eff}$

**Note:** This formula may not be applicable to a ship having diesel-electric propulsion, turbine propulsion or hybrid propulsion system, except for cruise passenger ships and LNG carriers.

Ships falling into the scope of EEDI requirement can use their attained EEDI calculated in accordance with the *2018 Guidelines on the method of calculation of the attained EEDI for new ships* (resolution MEPC.308(73), as amended, the "EEDI Calculation Guidelines" hereafter) as the attained EEXI if the value of the attained EEDI is equal to or less than that of the required EEXI.

### 2.2 Parameters

For calculation of the attained EEXI by the formula in paragraph 2.1, parameters under the EEDI Calculation Guidelines apply, unless expressly provided otherwise. In referring to the aforementioned guidelines, the terminology "EEDI" should be read as "EEXI".

#### 2.2.1 $P_{ME(i)}$ ; Power of main engines

In cases where overridable Shaft / Engine Power Limitation is installed in accordance with the *2021 Guidelines on the shaft / engine power limit to comply with the EEXI requirements and use of a power reserve* (resolution MEPC.335(76)),  $P_{ME(i)}$  is 83% of the limited installed power ( $MCR_{lim}$ ) or 75% of the original installed power ( $MCR$ ), whichever is lower, for each main engine ( $i$ ). In cases where the overridable Shaft / Engine Power Limitation and shaft generator(s) are installed, in referring to paragraph 2.2.5.2 (option 1) of the EEDI Calculation Guidelines, " $MCR_{ME}$ " should be read as " $MCR_{lim}$ ".

For LNG carriers having steam turbine or diesel electric propulsion,  $P_{ME(i)}$  is 83% of the limited installed power ( $MCR_{lim}$ ,  $MPP_{lim}$ ), divided by the electrical efficiency in case of diesel electric propulsion system, for each main engine ( $i$ ). For LNG carriers, the power from combustion of

the excessive natural boil-off gas in the engines or boilers to avoid releasing to the atmosphere or unnecessary thermal oxidation should be deducted from  $P_{ME(i)}$  with the approval of the verifier.

## 2.2.2 $P_{AE(i)}$ ; Power of auxiliary engines

2.2.2.1  $P_{AE(i)}$  is calculated in accordance with paragraph 2.2.5.6 of the EEDI Calculation Guidelines.

2.2.2.2 For ships where power of auxiliary engines ( $P_{AE}$ ) value calculated by paragraphs 2.2.5.6.1 to 2.2.5.6.3 of the EEDI Calculation Guidelines is significantly different from the total power used at normal seagoing, e.g. in cases of passenger ships, the  $P_{AE}$  value should be estimated by the consumed electric power (excluding propulsion) in conditions when the ship is engaged in a voyage at reference speed ( $V_{ref}$ ) as given in the electric power table, divided by the average efficiency of the generator(s) weighted by power (see appendix 2 of the EEDI Calculation Guidelines).

2.2.2.3 In cases where the electric power table is not available, the  $P_{AE}$  value may be approximated either by:

- .1 annual average figure of  $P_{AE}$  at sea from onboard monitoring obtained prior to the EEXI certification;
- .2 for cruise passenger ships, approximated value of power of auxiliary engines ( $P_{AE,app}$ ), as defined below:

$$P_{AE,app} = 0.1193 \times GT + 1814.4 \quad [\text{kW}]$$

- .3 for ro-ro passenger ships, approximated value of power of auxiliary engines ( $P_{AE,app}$ ), as defined below:

$$P_{AE,app} = 0.866 \times GT^{0.732} \quad [\text{kW}]$$

## 2.2.3 $V_{ref}$ ; Ship speed

2.2.3.1 For ships falling into the scope of the EEDI requirement, the ship speed  $V_{ref}$  should be obtained from an approved speed-power curve as defined in the *2014 Guidelines on survey and certification of the Energy Efficiency Design Index (EEDI)*, as amended (resolution MEPC.254(67), as amended).

2.2.3.2 For ships not falling into the scope of the EEDI requirement, the ship speed  $V_{ref}$  should be obtained from an estimated speed-power curve as defined in the *2021 Guidelines on survey and certification of the attained EEXI* (resolution MEPC.334(76)).

2.2.3.3 For ships not falling into the scope of the EEDI requirement but whose sea trial results, which may have been calibrated by the tank test, under the EEDI draught and the sea condition as specified in paragraph 2.2.2 of the EEDI Calculation Guidelines are included in the sea trial report, the ship speed  $V_{ref}$  may be obtained from the sea trial report:

$$V_{ref} = V_{S,EEDI} \times \left[ \frac{P_{ME}}{P_{S,EEDI}} \right]^{\frac{1}{3}} \quad [\text{knot}]$$

where,

$V_{S,EEDI}$ , is the sea trial service speed under the EEDI draught; and

$P_{S,EEDI}$  is power of the main engine corresponding to  $V_{S,EEDI}$ .

2.2.3.4 For containerhips, bulk carriers or tankers not falling into the scope of the EEDI requirement but whose sea trial results, which may have been calibrated by the tank test, under the design load draught and sea condition as specified in paragraph 2.2.2 of the EEDI Calculation Guidelines are included in the sea trial report, the ship speed  $V_{ref}$  may be obtained from the sea trial report:

$$V_{ref} = k^{\frac{1}{3}} \times \left( \frac{DWT_{S,service}}{Capacity} \right)^{\frac{2}{9}} \times V_{S,service} \times \left[ \frac{P_{ME}}{P_{S,service}} \right]^{\frac{1}{3}} \quad [\text{knot}]$$

where,

$V_{S,service}$  is the sea trial service speed under the design load draught;

$DWT_{S,service}$  is the deadweight under the design load draught;

$P_{S,service}$  is the power of the main engine corresponding to  $V_{S,service}$ ;

$k$  is the scale coefficient, which should be:

- .1 0.95 for containerhips with 120,000 DWT or less;
- .2 0.93 for containerhips with more than 120,000 DWT;
- .3 0.97 for bulk carrier with 200,000 DWT or less;
- .4 1.00 for bulk carrier with more than 200,000 DWT;
- .5 0.97 for tanker with 100,000 DWT or less; and
- .6 1.00 for tanker with more than 100,000 DWT.

2.2.3.5 In cases where the speed-power curve is not available or the sea trial report does not contain the EEDI or design load draught condition, the ship speed  $V_{ref}$  can be approximated by  $V_{ref,app}$  to be obtained from statistical mean of distribution of ship speed and engine power, as defined below:

$$V_{ref,app} = (V_{ref,avg} - m_V) \times \left[ \frac{\sum P_{ME}}{0.75 \times MCR_{avg}} \right]^{\frac{1}{3}} \quad [\text{knot}]$$

For LNG carriers having diesel electric propulsion system and cruise passenger ship having non-conventional propulsion,

$$V_{ref,app} = (V_{ref,avg} - m_V) \times \left[ \frac{\sum MPP_{Motor}}{MPP_{avg}} \right]^{\frac{1}{3}} \quad [\text{knot}]$$

where,

$V_{ref,avg}$  is a statistical mean of distribution of ship speed in given ship type and ship size, to be calculated as follows:

$$V_{ref,avg} = A \times B^C$$

where

A, B and C are the parameters given in the appendix;

$m_V$  is a performance margin of a ship, which should be 5% of  $V_{ref,avg}$  or one knot, whichever is lower; and

$MCR_{avg}$  is a statistical mean of distribution of MCRs for main engines and  $MPP_{avg}$  is a statistical mean of distribution of MPPs for motors in given ship type and ship size, to be calculated as follows:

$$MCR_{avg} \text{ or } MPP_{avg} = D \times E^F$$

where

D, E and F are the parameters given in the appendix;

In cases where the overridable Shaft / Engine Power Limitation is installed, the ship speed  $V_{ref}$  approximated by  $V_{ref,app}$  should be calculated as follows:

$$V_{ref,app} = (V_{ref,avg} - m_V) \times \left[ \frac{\sum P_{ME}}{0.75 \times MCR_{avg}} \right]^{\frac{1}{3}} \quad [\text{knot}]$$

For LNG carriers having diesel electric propulsion system and cruise passenger ship having non-conventional propulsion, the ship speed  $V_{ref}$  approximated by  $V_{ref,app}$  should be calculated as follows:

$$V_{ref,app} = (V_{ref,avg} - m_V) \times \left[ \frac{\sum MPP_{lim}}{MPP_{avg}} \right]^{\frac{1}{3}}$$

2.2.3.6 Notwithstanding the above, in cases where the energy saving device\* is installed, the effect of the device may be reflected in the ship speed  $V_{ref}$  with the approval of the verifier, based on the following methods in accordance with defined quality and technical standards:

- .1 sea trials after installation of the device; and/or
- .2 dedicated model tests; and/or
- .3 numerical calculations.

---

\* Devices that shift the power curve, which results in the change of  $P_P$  and  $V_{ref}$ , as specified in MEPC.1/Circ.815 on 2013 Guidance on treatment of innovative energy efficiency technologies for calculation and verification of the attained EEDI.



## 2.2.4 SFC; Certified specific fuel consumption

In cases where overridable Shaft / Engine Power Limitation is installed, the *SFC* corresponding to the  $P_{ME}$  should be interpolated by using *SFCs* listed in an applicable test report included in an approved NO<sub>x</sub> Technical File of the main engine as defined in paragraph 1.3.15 of the NO<sub>x</sub> Technical Code.

Notwithstanding the above, the *SFC* specified by the manufacturer or confirmed by the verifier may be used.

For those engines which do not have a test report included in the NO<sub>x</sub> Technical File and which do not have the *SFC* specified by the manufacturer or confirmed by the verifier, the *SFC* can be approximated by  $SFC_{app}$  defined as follows:

$$SFC_{ME,app} = 190 [g/kWh]$$

$$SFC_{AE,app} = 215 [g/kWh]$$

## 2.2.5 C<sub>F</sub>; Conversion factor between fuel consumption and CO<sub>2</sub> emission

For those engines which do not have a test report included in the NO<sub>x</sub> Technical File and which do not have the *SFC* specified by the manufacturer, the  $C_F$  corresponding to  $SFC_{app}$  should be defined as follows:

$$C_F = 3.114 [t \cdot CO_2/t \cdot Fuel] \text{ for diesel ships (incl. HFO use in practice)}$$

Otherwise, paragraph 2.2.1 of the EEDI Calculation Guidelines applies.

## 2.2.6 Correction factor for ro-ro cargo and ro-ro passenger ships ( $f_{jRoRo}$ )

For ro-ro cargo and ro-ro passenger ships,  $f_{jRoRo}$  is calculated as follows:

$$f_{jRoRo} = \frac{1}{F_{nL}^\alpha \cdot \left(\frac{L_{pp}}{B_S}\right)^\beta \cdot \left(\frac{B_S}{d_S}\right)^\gamma \cdot \left(\frac{L_{pp}}{V^{1/3}}\right)^\delta} \quad ; \text{ if } f_{jRoRo} > 1 \text{ then } f_j = 1$$

where the Froude number,  $F_{nL}$ , is defined as:

$$F_{nL} = \frac{0.5144 \cdot V_{ref,F}}{\sqrt{L_{pp} \cdot g}}$$

where  $V_{ref,F}$  is the ship design speed corresponding to 75% of  $MCR_{ME}$ :

and the exponents  $\alpha$ ,  $\beta$ ,  $\gamma$  and  $\delta$  are defined as follows:

Ship type	Exponent:			
	$\alpha$	$\beta$	$\gamma$	$\delta$
Ro-ro cargo ship	2.00	0.50	0.75	1.00
Ro-ro passenger ship	2.50	0.75	0.75	1.00

### **2.2.7 Cubic capacity correction factor for ro-ro cargo ships (vehicle carrier) ( $f_{cVEHICLE}$ )**

For ro-ro cargo ships (vehicle carrier) having a DWT/GT ratio of less than 0.35, the following cubic capacity correction factor,  $f_{cVEHICLE}$ , should apply:

$$f_{cVEHICLE} = \left( \frac{(DWT/GT)}{0.35} \right)^{-0,8}$$

Where DWT is the capacity and GT is the gross tonnage in accordance with the International Convention of Tonnage Measurement of Ships 1969, annex I, regulation 3.

APPENDIX

Parameters to calculate  $V_{ref,avg}$

Ship type	A	B	C
Bulk carrier	10.6585	DWT of the ship	0.02706
Gas carrier	7.4462	DWT of the ship	0.07604
Tanker	8.1358	DWT of the ship	0.05383
Containership	3.2395	DWT of the ship where DWT ≤ 80,000 80,000 where DWT > 80,000	0.18294
General cargo ship	2.4538	DWT of the ship	0.18832
Refrigerated cargo carrier	1.0600	DWT of the ship	0.31518
Combination carrier	8.1391	DWT of the ship	0.05378
LNG carrier	11.0536	DWT of the ship	0.05030
Ro-ro cargo ship (vehicle carrier)	16.6773	DWT of the ship	0.01802
Ro-ro cargo ship	8.0793	DWT of the ship	0.09123
Ro-ro passenger ship	4.1140	DWT of the ship	0.19863
Cruise passenger ship having non-conventional propulsion	5.1240	GT of the ship	0.12714

Parameters to calculate  $MCR_{avg}$  or  $MPP_{avg}$  (= D x E<sup>F</sup>)

Ship type	D	E	F
Bulk carrier	23.7510	DWT of the ship	0.54087
Gas carrier	21.4704	DWT of the ship	0.59522
Tanker	22.8415	DWT of the ship	0.55826
Containership	0.5042	DWT of the ship where DWT ≤ 95,000 95,000 where DWT > 95,000	1.03046
General cargo ship	0.8816	DWT of the ship	0.92050
Refrigerated cargo carrier	0.0272	DWT of the ship	1.38634
Combination carrier	22.8536	DWT of the ship	0.55820
LNG carrier	20.7096	DWT of the ship	0.63477
Ro-ro cargo ship (vehicle carrier)	262.7693	DWT of the ship	0.39973
Ro-ro cargo ship	37.7708	DWT of the ship	0.63450
Ro-ro passenger ship	9.1338	DWT of the ship	0.91116
Cruise passenger ship having non-conventional propulsion	1.3550	GT of the ship	0.88664

Calculation of parameters to calculate  $V_{ref,avg}$  and  $MCR_{avg}$

Data sources

1 IHS Fairplay (IHSF) database with the following conditions are used.

Ship type	Ship size	Delivered period	Type of propulsion systems	Population
Bulk carrier	≥ 10,000 DWT	From 1 January 1999 to 1 January 2009	Conventional	2,433
Gas carrier	≥ 2,000 DWT		Conventional	292
Tanker	≥ 4,000 DWT		Conventional	3,345
Containership	≥ 10,000 DWT		Conventional	2,185
General cargo ship	≥ 3,000 DWT		Conventional	1,673
Refrigerated cargo carrier	≥ 3,000 DWT		Conventional	53
Combination carrier	≥ 4,000 DWT		Conventional	3,351
LNG carrier	≥ 10,000 DWT		Conventional, Non-conventional	185
Ro-ro cargo ship (vehicle carrier)	≥ 10,000 DWT		Conventional	301
Ro-ro cargo ship	≥ 1,000 DWT		From 1 January 1998 to 31 December 2010	Conventional
Ro-ro passenger ship	≥ 250 DWT	Conventional		350
Cruise passenger ship having non-conventional propulsion	≥ 25,000 GT	From 1 January 1999 to 1 January 2009	Non-conventional	93

2 Data sets with blank/zero "Service speed", "Capacity" and/or Total kW of M/E" are removed.

3 Ship type is in accordance with table 1 and table 2 of resolution MEPC.231(65) on 2013 Guidelines for calculation of reference lines for use with the Energy Efficiency Design Index (EEDI). However, "Gas carrier" does not include "LNG carrier". Parameters for "LNG carrier" are given separately.

\*\*\*

**ANNEX 8**

**RESOLUTION MEPC.334(76)  
(adopted on 17 June 2021)**

**2021 GUIDELINES ON SURVEY AND CERTIFICATION OF THE ATTAINED ENERGY  
EFFICIENCY EXISTING SHIP INDEX (EEXI)**

THE MARINE ENVIRONMENT PROTECTION COMMITTEE,

RECALLING Article 38(a) of the Convention on the International Maritime Organization concerning the functions of the Marine Environment Protection Committee conferred upon it by international conventions for the prevention and control of marine pollution from ships,

NOTING that it adopted, by resolution MEPC.328(76), the 2021 revised MARPOL Annex VI, which is expected to enter into force on 1 November 2022 upon its deemed acceptance on 1 May 2022,

NOTING IN PARTICULAR that the 2021 revised MARPOL Annex VI contains amendments concerning mandatory goal-based technical and operational measures to reduce carbon intensity of international shipping,

NOTING FURTHER that regulation 5 (Surveys) of MARPOL Annex VI, as amended, requires that ships to which chapter 4 applies shall also be subject to survey and certification taking into account guidelines developed by the Organization,

RECOGNIZING that the aforementioned amendments to MARPOL Annex VI require relevant guidelines for uniform and effective implementation of the regulations and to provide sufficient lead time for industry to prepare,

HAVING CONSIDERED, at its seventy-sixth session, draft *2021 Guidelines on survey and certification of the Energy Efficiency Existing Ship Index (EEXI)*,

- 1 ADOPTS the *2021 Guidelines on survey and certification of the Energy Efficiency Existing Ship Index (EEXI)*, as set out in the annex to the present resolution;
- 2 INVITES Administrations to take the annexed Guidelines into account when developing and enacting national laws which give force to and implement requirements set forth in regulation 5 of MARPOL Annex VI;
- 3 REQUESTS the Parties to MARPOL Annex VI and other Member Governments to bring the annexed Guidelines to the attention of masters, seafarers, shipowners, ship operators and any other interested parties;
- 4 AGREES to keep the Guidelines under review in light of experience gained with their implementation and in light of the review of EEXI regulations to be completed by the Organization by 1 January 2026 as identified in regulation 25.3 of MARPOL Annex VI.

ANNEX

**2021 GUIDELINES ON SURVEY AND CERTIFICATION OF THE ATTAINED ENERGY  
EFFICIENCY EXISTING SHIP INDEX (EEXI)**

**Table of contents**

1	GENERAL
2	DEFINITIONS
3	APPLICATION
4	PROCEDURES FOR SURVEY AND CERTIFICATION
4.1	General
4.2	Verification of the attained EEXI
4.3	Verification of the attained EEXI in case of major conversion
APPENDIX	Sample of EEXI Technical File

## 1 GENERAL

The purpose of these guidelines is to assist verifiers of the Energy Efficiency Existing Ship Index (EEXI) of ships in conducting the survey and certification of the EEXI, in accordance with regulations 5, 6, 7, 8 and 9 of MARPOL Annex VI, and assist shipowners, shipbuilders, manufacturers and other interested parties in understanding the procedures for the survey and certification of the EEXI.

## 2 DEFINITIONS<sup>1</sup>

2.1 *Verifier* means an Administration, or organization duly authorized by it, which conducts the survey and certification of the EEXI in accordance with regulations 5, 6, 7, 8 and 9 of MARPOL Annex VI and these Guidelines.

2.2 *Ship of the same type* means a ship the hull form (expressed in the lines such as sheer plan and body plan), excluding additional hull features such as fins, and principal particulars of which are identical to that of the base ship.

2.3 *Tank test* means model towing tests, model self-propulsion tests and model propeller open water tests. Numerical calculations may be accepted as equivalent to model propeller open water tests or used to complement the tank tests conducted (e.g. to evaluate the effect of additional hull features such as fins, etc. on ships' performance), or as a replacement for model tests provided that the methodology and numerical model used have been validated/calibrated against parent hull sea trials and/or model tests, with the approval of the verifier.

2.4 *MARPOL* means the International Convention for the Prevention of Pollution from Ships, 1973, as modified by the Protocols of 1978 and 1997 relating thereto, as amended.

2.5 For the purpose of these Guidelines, the definitions in MARPOL Annex VI, as amended, apply.

## 3 APPLICATION

These Guidelines should be applied to ships for which an application for a survey for verification of the ship's EEXI specified in regulation 5 of MARPOL Annex VI has been submitted to a verifier.

## 4 PROCEDURES FOR SURVEY AND CERTIFICATION

### 4.1 General

4.1.1 The attained EEXI should be calculated in accordance with regulation 23 of MARPOL Annex VI and the *2021 Guidelines on the method of calculation of the attained Energy Efficiency Existing Ship Index (EEXI)* (resolution MEPC.333(76)) (EEXI Calculation Guidelines).

4.1.2 The 2013 Guidance on treatment of innovative energy efficiency technologies for calculation and verification of the attained EEDI (MEPC.1/Circ.815) should be applied for calculation of the attained EEXI, if applicable.

---

<sup>1</sup> Other terms used in these Guidelines have the same meaning as those defined in the *2018 Guidelines on the method of calculation of the attained EEDI for new ships* (resolution MEPC.308(73), as amended) and the *2021 Guidelines on the method of calculation of the attained EEXI* (resolution MEPC.333(76)).

4.1.3 The information used in the verification process may contain confidential information of submitters, including shipyards, which requires Intellectual Property Rights (IPR) protection. In the case where the submitter wants a non-disclosure agreement with the verifier, the additional information should be provided to the verifier upon mutually agreed terms and conditions.

## 4.2 Verification of the attained EEXI

4.2.1 For verification of the attained EEXI, an application for a survey and an EEXI Technical File containing the necessary information for the verification and other relevant background documents should be submitted to a verifier, unless the attained EEDI of the ship satisfies the required EEXI.

4.2.2 The EEXI Technical File should be written at least in English. The EEXI Technical File should include, but not be limited to:

- .1 deadweight (DWT) or gross tonnage (GT) for ro-ro passenger ship and cruise passenger ship having non-conventional propulsion;
- .2 the rated installed power ( $MCR$ ) of the main and auxiliary engines;
- .3 the limited installed power ( $MCR_{lim}$ ) in cases where the overridable Shaft / Engine Power Limitation system is installed;
- .4 the ship speed ( $V_{ref}$ );
- .5 the approximate ship speed ( $V_{ref,app}$ ) for pre-EEDI ships in cases where the speed-power curve is not available, as specified in paragraph 2.2.3.5 of the EEXI Calculation Guidelines;
- .6 an approved speed-power curve under the EEDI condition as specified in paragraph 2.2 of the EEDI Calculation Guidelines, which is described in the EEDI Technical File, in cases where regulation 22 of MARPOL Annex VI (Attained EEDI) is applied;
- .7 an estimated speed-power curve under the EEDI condition, or under a different load draught to be calibrated to the EEDI condition, obtained from tank test and/or numerical calculations, if available;
- .8 estimation process and methodology of the power curves, as necessary, including documentation on consistency with the defined quality standards (e.g. ITTC 7.5-03-01-02 and ITTC 7.5-03-01-04 in their latest revisions) and the verification of the numerical set-up with parent hull or the reference set of comparable ships in case of using numerical calculations;
- .9 a sea trial report including sea trial results, which may have been calibrated by the tank test, under the sea condition as specified in paragraph 2.2.2 of the EEDI Calculation Guidelines, if available;
- .10 calculation process of  $V_{ref,app}$  for pre-EEDI ships in cases where the speed-power curve is not available, as specified in paragraph 2.2.3.5 of the EEXI Calculation Guidelines;
- .11 type of fuel;



- .12 the specific fuel consumption (*SFC*) of the main and auxiliary engines, as specified in paragraph 2.2.3 of the EEXI Calculation Guidelines;
- .13 the electric power table<sup>2</sup> for certain ship types, as necessary, as defined in the EEDI Calculation Guidelines;
- .14 the documented record of annual average figure of the auxiliary engine load at sea obtained prior to the date of application for a survey for verification of the ship's EEXI, as specified in paragraph 2.2.2.3 of the EEXI Calculation Guidelines, if applicable;
- .15 calculation process of  $P_{AE,app}$ , as specified in paragraph 2.2.2.3 of the EEXI Calculation Guidelines, if applicable;
- .16 principal particulars, ship type and the relevant information to classify the ship as such a ship type, classification notations and an overview of the propulsion system and electricity supply system on board;
- .17 description of energy saving equipment, if available;
- .18 calculated value of the attained EEXI, including the calculation summary, which should contain, at a minimum, each value of the calculation parameters and the calculation process used to determine the attained EEXI; and
- .19 for LNG carriers:
  - .1 type and outline of propulsion systems (such as direct drive diesel, diesel electric, steam turbine);
  - .2 LNG cargo tank capacity in m<sup>3</sup> and BOR as defined in paragraph 2.2.5.6.3 of the EEDI Calculation Guidelines;
  - .3 shaft power of the propeller shaft after transmission gear at 100% of the rated output of motor ( $MPP_{Motor}$ ) and  $\eta_{(i)}$  for diesel electric;
  - .4 shaft power of the propeller shaft after transmission gear at the de-rated output of motor ( $MPP_{Motor,lim}$ ) in cases where the overridable Shaft / Engine Power Limitation is installed;
  - .5 maximum continuous rated power ( $MCR_{SteamTurbine}$ ) for steam turbine;
  - .6 limited maximum continuous rated power ( $MCR_{SteamTurbine,lim}$ ) for steam turbine in cases where the overridable Shaft / Engine Power Limitation is installed; and
  - .7  $SFC_{SteamTurbine}$  for steam turbine, as specified in paragraph 2.2.7.2 of the EEDI Calculation Guidelines. If the calculation is not available from the manufacturer,  $SFC_{SteamTurbine}$  may be calculated by the submitter.

A sample of an EEXI Technical File is provided in the appendix.

<sup>2</sup> Electric power tables should be validated separately, taking into account the guidelines set out in appendix 2 of the 2014 *Guidelines on survey and certification of the Energy Efficiency Design Index (EEDI)* (resolution MEPC.254(67), as amended by resolutions MEPC.261(68) and MEPC.309(73)); consolidated text: MEPC.1/Circ.855/Rev.2, as may be further amended).

4.2.3 The *SFC* should be corrected to the value corresponding to the ISO standard reference conditions using the standard lower calorific value of the fuel oil, referring to ISO 15550:2002 and ISO 3046-1:2002. For the confirmation of the *SFC*, a copy of the approved NO<sub>x</sub> Technical File and documented summary of the correction calculations should be submitted to the verifier.

4.2.4 For ships equipped with dual-fuel engine(s) using LNG and fuel oil, the *C<sub>F</sub>*-factor for gas (LNG) and the specific fuel consumption (*SFC*) of gas fuel should be used by applying the criteria specified in paragraph 4.2.3 of the *2014 Guidelines on survey and certification of the Energy Efficiency Design Index (EEDI)*, as amended,<sup>3</sup> as a basis for the guidance of the Administration.

4.2.5 Notwithstanding paragraphs 4.2.3 and 4.2.4, in cases where overridable Shaft / Engine Power Limitation is installed, or in cases where engines do not have a test report included in the NO<sub>x</sub> Technical File, *SFC* should be calculated in accordance with paragraph 2.2.3 of the EEXI Calculation Guidelines. For this purpose, actual performance records of the engine may be used if satisfactory and acceptable to the verifier.

4.2.6 The verifier may request further information from the submitter, as specified in paragraph 4.2.7 of the EEDI Survey and Certification Guidelines, in addition to that contained in the EEXI Technical File, as necessary, to examine the calculation process of the attained EEXI.

4.2.7 In cases where the sea trial report as specified in paragraph 4.2.2.9 is submitted, the verifier should request further information from the submitter to confirm that:

- .1 the sea trial was conducted in accordance with the conditions specified in paragraphs 4.3.3, 4.3.4 and 4.3.7 of the EEDI Survey and Certification Guidelines, as applicable;
- .2 sea conditions were measured in accordance with ISO 15016:2002 or the equivalent if satisfactory and acceptable to the verifier;
- .3 ship speed was measured in accordance with ISO 15016:2002 or the equivalent if satisfactory and acceptable to the verifier; and
- .4 the measured ship speed was calibrated, if necessary, by taking into account the effects of wind, tide, waves, shallow water and displacement in accordance with ISO 15016:2002 or the equivalent which may be acceptable provided that the concept of the method is transparent for the verifier and publicly available/accessible.

4.2.8 The estimated speed-power curve obtained from the tank test and/or numerical calculations and/or the sea trial results calibrated by the tank test should be reviewed on the basis of the relevant documents in accordance with the EEDI Survey and Certification Guidelines, the defined quality standards (e.g. ITTC 7.5-03-01-02 and ITTC 7.5-03-01-04 in their latest revisions) and the verification of the numerical set-up with parent hull or the reference set of comparable ships.

4.2.9 In cases where the overridable Shaft / Engine Power Limitation system is installed, the verifier should confirm that the system is appropriately installed and sealed in accordance with the *2021 Guidelines on the Shaft / Engine Power Limitation system to comply with the EEXI requirements and use of a power reserve* (resolution MEPC.335(76)) and that a verified Onboard Management Manual (OMM) for overridable Shaft / Engine Power Limitation is on board the ship.

---

<sup>3</sup> Resolution MEPC.254(67), as amended.

### **4.3 Verification of the attained EEXI in case of major conversion**

4.3.1 In cases of a major conversion of a ship taking place at or after the completion date of the survey for EEXI verification specified in regulation 5.4.7 of MARPOL Annex VI, the shipowner should submit to a verifier an application for a general or partial survey with the EEXI Technical File duly revised, based on the conversion made and other relevant background documents.

4.3.2 The background documents should include as a minimum, but are not limited to:

- .1 details of the conversion;
- .2 EEXI parameters changed after the conversion and the technical justifications for each respective parameter;
- .3 reasons for other changes made in the EEXI Technical File, if any; and
- .4 calculated value of the attained EEXI with the calculation summary, which should contain, as a minimum, each value of the calculation parameters and the calculation process used to determine the attained EEXI after the conversion.

4.3.3 The verifier should review the revised EEXI Technical File and other documents submitted and verify the calculation process of the attained EEXI to ensure that it is technically sound and reasonable and follows regulation 23 of MARPOL Annex VI and the EEXI Calculation Guidelines.

4.3.4 For verification of the attained EEXI after the major conversion, speed trials of the ship may be conducted, as necessary.

APPENDIX

**SAMPLE OF EEXI TECHNICAL FILE**

**1 Data**

1.1 General information

Shipowner	XXX Shipping Line
Shipbuilder	XXX Shipbuilding Company
Hull no.	12345
IMO no.	94112XX
Ship type	Bulk carrier

1.2 Principal particulars

Length overall	250.0 m
Length between perpendiculars	240.0 m
Breadth, moulded	40.0 m
Depth, moulded	20.0 m
Summer load line draught, moulded	14.0 m
Deadweight at summer load line draught	150,000 tons

1.3 Main engine

Manufacturer	XXX Industries
Type	6J70A
Maximum continuous rating ( $MCR_{ME}$ )	15,000 kW x 80 rpm
Limited maximum continuous rating with the Engine Power Limitation installed ( $MCR_{ME,lim}$ )	9,940 kW x 70 rpm
SFC at 75% of $MCR_{ME}$ or 83% of $MCR_{ME,lim}$	166.5 g/kWh
Number of sets	1
Fuel type	Diesel Oil

1.4 Auxiliary engine

Manufacturer	XXX Industries
Type	5J-200
Maximum continuous rating ( $MCR_{AE}$ )	600 kW x 900 rpm
SFC at 50% $MCR_{AE}$	220.0 g/kWh
Number of sets	3
Fuel type	Diesel Oil

1.5 Ship speed

Ship speed ( $V_{ref}$ ) (with the Engine Power Limitation installed)	13.20 knots
---	-------------

## 2 Power curve

(Example 1; case of the EEDI ship)

An approved speed-power curve contained in the EEDI Technical File is shown in figure 2.1.

(Example 2; case of the pre-EEDI ship)

An estimated speed-power curve obtained from the tank test and/or numerical calculations, if available, is also shown in figure 2.1.

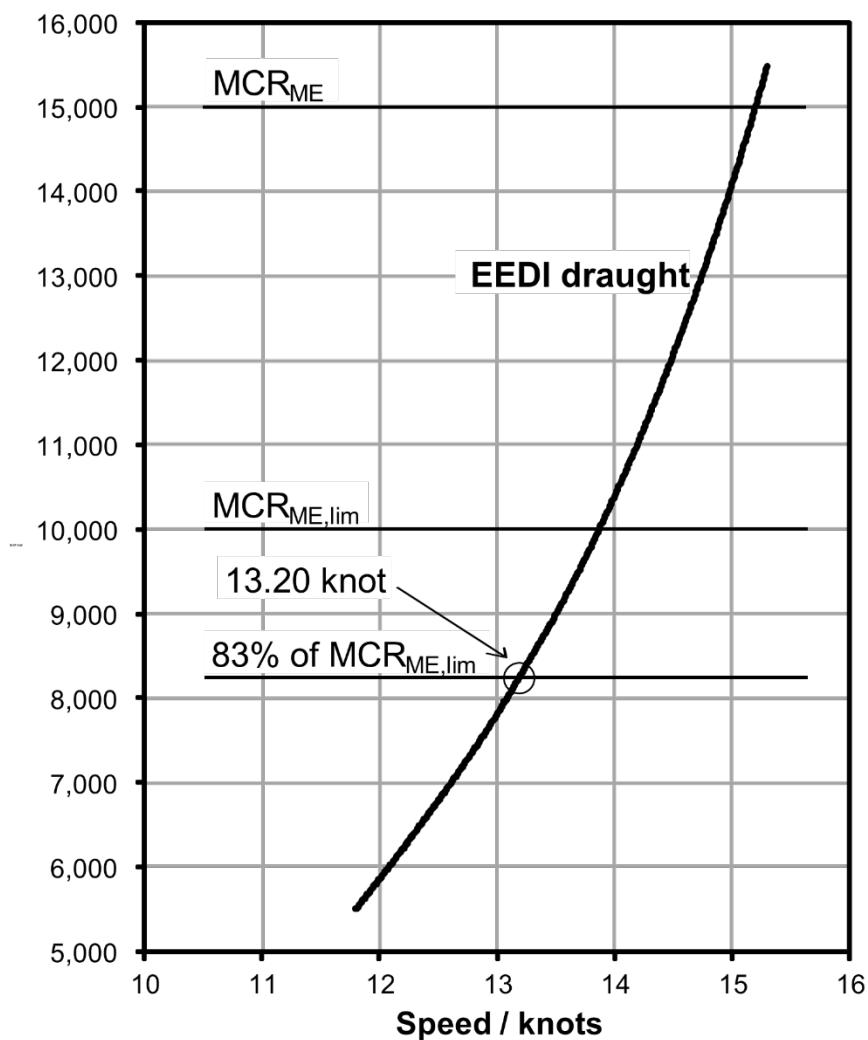
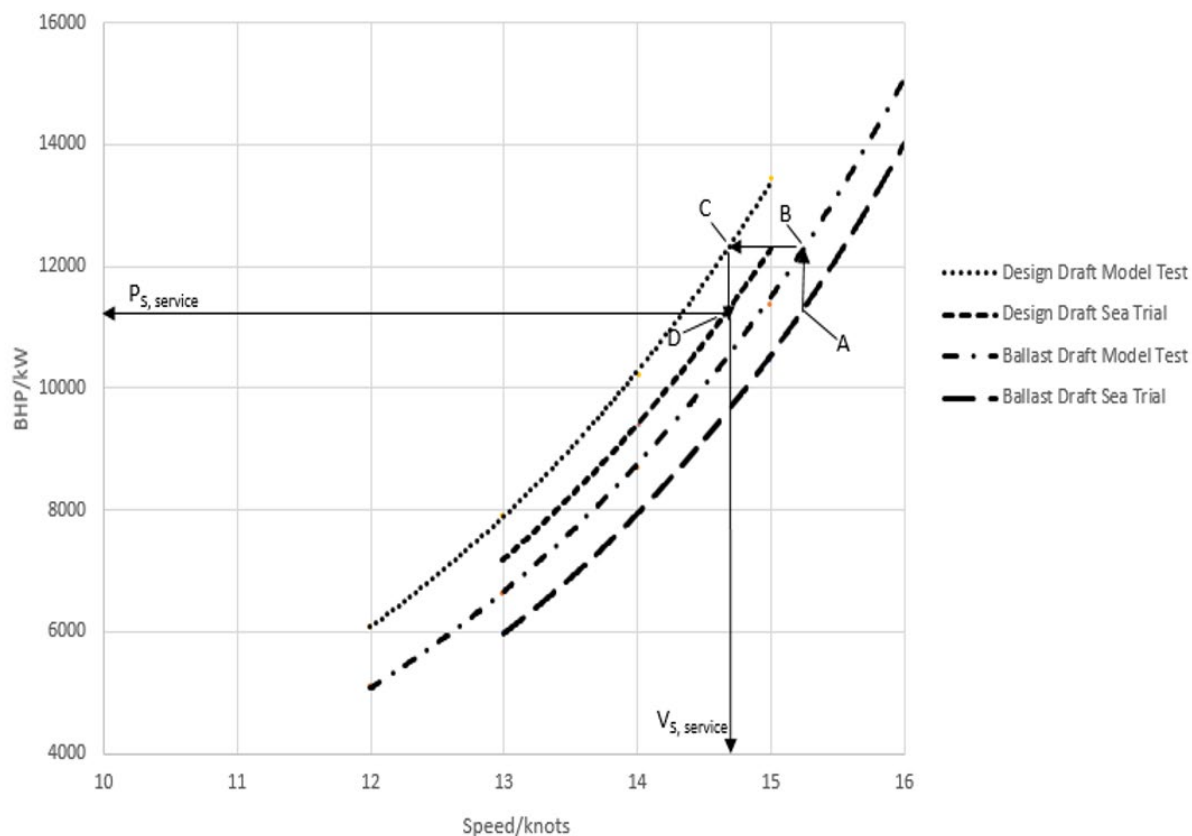

Figure 2.1: Power curve

(Example 3; case of the pre-EEDI ship with sea trial result calibrated to a different load draught)

An estimated speed-power curve under a ballast draught calibrated to the design load draught, obtained from the tank test and/or numerical calculations, if available, is shown in figure 2.2.



**Figure 2.2: Power curve**

### 3 Overview of propulsion system and electric power supply system

#### 3.1 Propulsion system

##### 3.1.1 Main engine

Refer to paragraph 1.3 of this appendix.

##### 3.1.2 Propeller

Type	Fixed pitch propeller
Diameter	7.0 m
Number of blades	4
Number of sets	1

#### 3.2 Electric power supply system

##### 3.2.1 Auxiliary engines

Refer to paragraph 1.4 of this appendix.

##### 3.2.2 Main generators

Manufacturer	XXX Electric
Rated output	560 kW (700 kVA) x 900 rpm
Voltage	AC 450 V
Number of sets	3

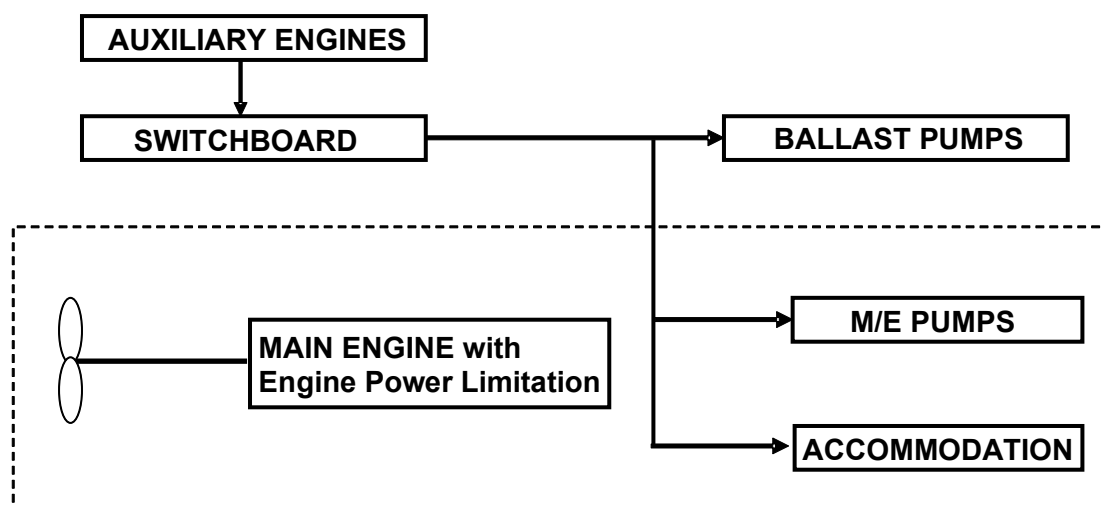

Figure 3.1: Schematic figure of propulsion and electric power supply system

#### 4 Estimation process of speed-power curve

(Example; case of pre-EEDI ship)

Speed-power curve is estimated based on model test results and/or numerical calculations, if available. The flow of the estimation processes is shown below.

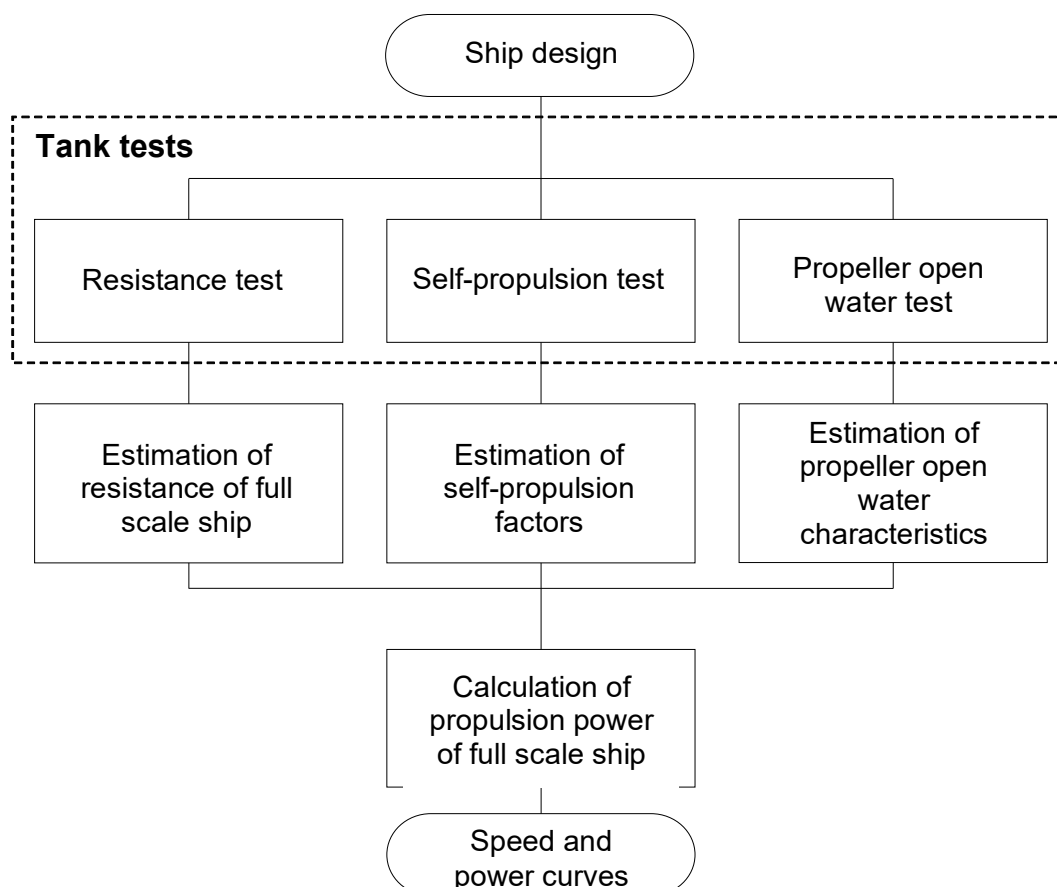

Figure 4: Flow chart of process for estimating speed-power curve from tank tests

## 5 Description of energy saving equipment

5.1 Energy saving equipment the effects of which are expressed as  $P_{AEff(i)}$  and/or  $P_{eff(i)}$  in the EEXI calculation formula

N/A

5.2 Other energy saving equipment

(Example)

5.2.1 Rudder fins

5.2.2 Rudder bulb

.....

(Specifications, schematic figures and/or photos, etc. for each piece of equipment or device should be indicated. Alternatively, attachment of a commercial catalogue may be acceptable.)

## 6 Calculated value of attained EEXI

6.1 Basic data

Type of ship	Capacity DWT	Speed $V_{ref}$ (knots)
Bulk carrier	150,000	13.20

6.2 Main engine

$MCR_{ME}$ (kW)	$MCR_{ME,lim}$ (kW)	$P_{ME}$ (kW)	Type of fuel	$C_{FME}$	$SFC_{ME}$ (g/kWh)
15,000	9,940	8,250	Diesel oil	3.206	166.5

6.3 Auxiliary engines

$P_{AE}$ (kW)	Type of fuel	$C_{FAE}$	$SFC_{AE}$ (g/kWh)
625	Diesel oil	3.206	220.0

6.4 Ice class

N/A

6.5 Innovative electrical energy-efficient technology

N/A

6.6 Innovative mechanical energy-efficient technology

N/A

6.7 Cubic capacity correction factor

N/A

6.8 Calculated value of attained EEXI



$$\begin{aligned}
 EEXI &= \frac{(\prod_{j=1}^M f_j)(\sum_{i=1}^{n_{ME}} P_{ME(i)} \cdot C_{FME(i)} \cdot SFC_{ME(i)}) + (P_{AE} \cdot C_{FAE} \cdot SFC_{AE})}{f_i \cdot f_c \cdot f_l \cdot Capacity \cdot f_w \cdot V_{ref} \cdot f_m} \\
 &+ \frac{\{(\prod_{j=1}^M f_j \cdot \sum_{i=1}^{n_{PTI}} P_{PTI(i)} - \sum_{i=1}^{n_{eff}} f_{eff(i)} \cdot P_{AE_{eff(i)}})\} \cdot C_{FAE} \cdot SFC_{AE}}{f_i \cdot f_c \cdot f_l \cdot Capacity \cdot f_w \cdot V_{ref} \cdot f_m} \\
 &- \frac{(\sum_{i=1}^{n_{eff}} f_{eff(i)} \cdot P_{eff(i)} \cdot C_{FME} \cdot SFC_{ME})}{f_i \cdot f_c \cdot f_l \cdot Capacity \cdot f_w \cdot V_{ref} \cdot f_m} \\
 &= \frac{1 \times (8250 \times 3.206 \times 166.5) + (625 \times 3.206 \times 220.0) + 0 - 0}{1 \times 1 \times 1 \times 150000 \times 1 \times 13.20 \times 1} \\
 &= 2.45 \text{ (g - CO}_2\text{/ton} \cdot \text{mile)}
 \end{aligned}$$

**attained EEXI: 2.45 g-CO<sub>2</sub>/ton mile**

\*\*\*



**ANNEX 9**

**RESOLUTION MEPC.335(76)  
(adopted on 17 June 2021)**

**2021 GUIDELINES ON THE SHAFT / ENGINE POWER LIMITATION SYSTEM TO  
COMPLY WITH THE EEXI REQUIREMENTS AND USE OF A POWER RESERVE**

THE MARINE ENVIRONMENT PROTECTION COMMITTEE,

RECALLING Article 38(a) of the Convention on the International Maritime Organization concerning the functions of the Marine Environment Protection Committee conferred upon it by international conventions for the prevention and control of marine pollution from ships,

NOTING that it adopted, by resolution MEPC.328(76), the 2021 revised MARPOL Annex VI, which is expected to enter into force on 1 November 2022 upon its deemed acceptance on 1 May 2022,

NOTING IN PARTICULAR that the 2021 revised MARPOL Annex VI contains amendments concerning mandatory goal-based technical and operational measures to reduce carbon intensity of international shipping,

NOTING FURTHER that ships may be equipped with a Shaft / Engine Power Limitation system in order to comply with regulation 25 (Required EEXI),

RECOGNIZING that the aforementioned amendments to MARPOL Annex VI require relevant guidelines for uniform and effective implementation of the regulations and to provide sufficient lead time for industry to prepare,

HAVING CONSIDERED, at its seventy-sixth session, draft *2021 Guidelines on the shaft / engine power limitation system to comply with the EEXI requirements and use of a power reserve*,

1 ADOPTS the *2021 Guidelines on the shaft / engine power limitation system to comply with the EEXI requirements and use of a power reserve*, as set out in the annex to the present resolution;

2 INVITES Administrations to take the annexed Guidelines into account when developing and enacting national laws which give force to and implement requirements set forth in regulations 23 and 25 of MARPOL Annex VI;

3 REQUESTS the Parties to MARPOL Annex VI and other Member Governments to bring the annexed Guidelines to the attention of masters, seafarers, shipowners, ship operators and any other interested parties;

4 AGREES to keep the Guidelines under review in light of experience gained with their implementation and in light of the review of EEXI regulations to be completed by the Organization by 1 January 2026 as identified in regulation 25.3 of MARPOL Annex VI;

5 NOTES that the Guidelines may be consolidated with possible future guidelines on the shaft / engine power limitation system under the EEDI framework as appropriate upon consideration by the Committee, taking into account circumstances and technical limitation of existing ships.

ANNEX

**2021 GUIDELINES ON THE SHAFT / ENGINE POWER LIMITATION SYSTEM TO  
COMPLY WITH THE EEXI REQUIREMENTS AND USE OF A POWER RESERVE**

**Table of contents**

0	General
1	Definitions
2	Technical requirements for the SHaPoLi / EPL system
3	Use of a power reserve by unlimiting the shaft / engine power limitation
4	Onboard Management Manual (OMM) for SHaPoLi / EPL
5	Demonstration of compliance of the SHaPoLi / EPL system

## 0 General

The purpose of these Guidelines is to provide technical and operational conditions that the SHaPoLi / EPL system should satisfy in complying with the EEXI requirements and in using a power reserve for existing ships. However, noting that guidelines on the SHaPoLi / EPL system under EEDI framework on new ships are currently considered at the Committee, these guidelines under EEXI and EEDI may be consolidated into one set of guidelines as appropriate upon consideration by the Committee, taking into account circumstances and technical limitation of existing ships.

## 1 Definitions

1.1 *Shaft power* means the mechanical power transmitted by the propeller shaft to the propeller hub. It is the product of the shaft torque and the shaft rotational speed. In case of multiple propeller shafts, the shaft power means the sum of the power transmitted to all propeller shafts.

1.2 *Engine power* means the mechanical power transmitted from the engine to the propeller shaft. In case of multiple engines, the engine power means the sum of the power transmitted from the engines to the propeller shafts.

1.3 *Overridable Shaft Power Limitation (SHaPoLi) system* means a verified and approved system for the limitation of the maximum shaft power by technical means that can only be overridden by the ship's master or the officer in charge of navigational watch (OICNW) for the purpose of securing the safety of a ship or saving life at sea. (See figure 1 for an illustration of engine load diagram.)

1.4 *Overridable Engine Power Limitation (EPL) system* means a verified and approved system for the limitation of the maximum engine power by technical means that can only be overridden by the ship's master or OICNW for the purpose of securing the safety of a ship or saving life at sea. (See figure 1 for an illustration of engine load diagram.)

1.5 *Power reserve* means shaft / engine power above the limited power which cannot be used in normal operation unless in the case when SHaPoLi / EPL is unlimited for the purpose of securing the ship safety.

1.6 *MARPOL* means the International Convention for the Prevention of Pollution from Ships, 1973, as modified by the Protocols of 1978 and 1997 relating thereto, as amended.

1.7 For the purpose of these Guidelines, the definitions in MARPOL Annex VI, as amended, apply.

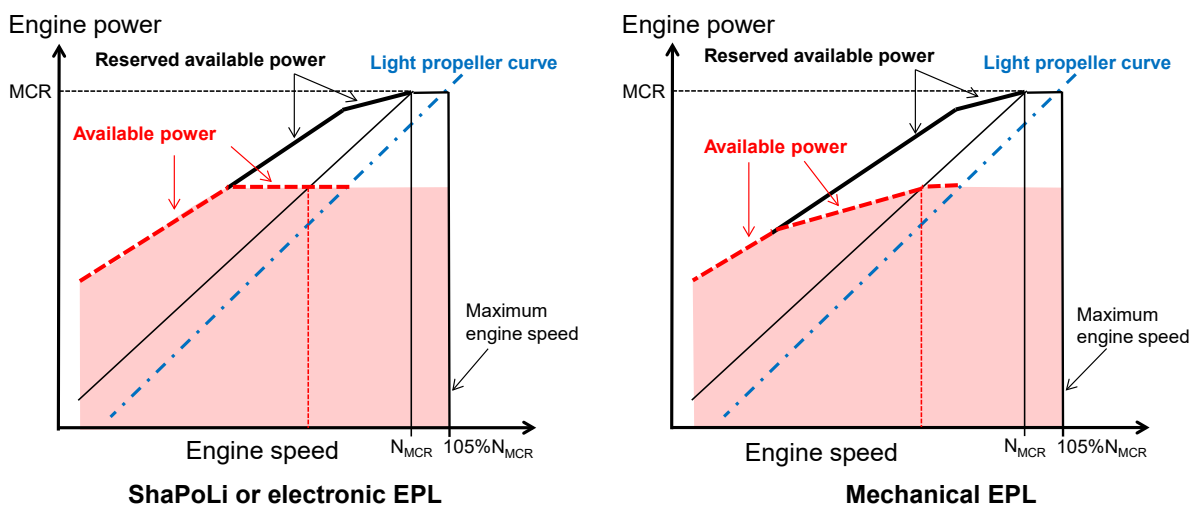

**Figure 1: Engine load diagram on Shaft/Engine Power Limitation**

## 2 Technical requirements for the SHaPoLi / EPL system

### 2.1 Required main systems

The SHaPoLi / EPL system should consist of the following main arrangements:

- .1 SHaPoLi:
  - .1 sensors for measuring the torque and rotational speed delivered to the propeller(s) of the ship. The system includes the amplifier and the analogue to the digital converter;
  - .2 a data recording and processing device for tracking and calculation of the data as given in paragraph 2.2.5.1 of these Guidelines; and
  - .3 a control unit for calculation and limitation of the power transmitted by the shaft to the propeller(s);
- .2 EPL:
  - .1 for the mechanically controlled engine, a sealing device which can physically lock the fuel index by using a mechanical stop screw sealed by wire or an equivalent device with governor limit setting so that the ship's crew cannot release the EPL without permission from the ship's master or OICNW, as shown in figure 2; or
  - .2 for the electronically controlled engine, fuel index limiter which can electronically lock the fuel index or direct limitation of the power in the engine's control system so that the ship's crew cannot release the EPL without permission from the ship's master or OICNW; and
  - .3 where technically possible and feasible, the Sha/PoLi/EPL system should be controlled from the ships' bridge and not require attendance in the machinery space by ship's personnel.

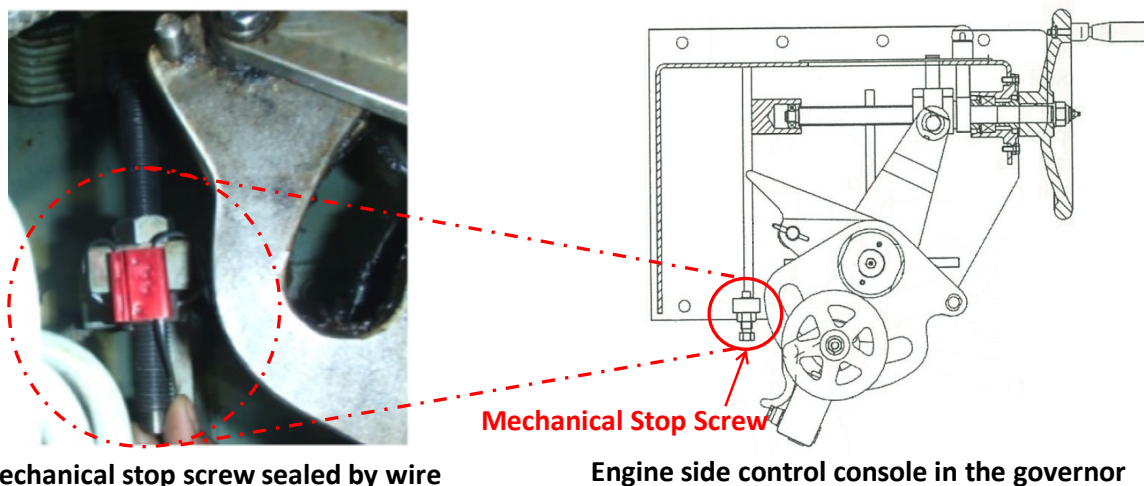

**Figure 2: Sealing of mechanical stop screw**

## 2.2 General system requirements

2.2.1 The SHaPoLi / EPL system should be non-permanent but should require the deliberate action of the ship's master or OICNW to enable the use of unlimited shaft / engine power (power reserve) of the ship. For systems that use a Password/PIN to control access to the power reserve override, attention should be paid to ensure that the necessary Password/PIN is always available when override is required.

2.2.2 For SHaPoLi / EPL system for the electronically controlled engine, the control unit should inform the ship's master or OICNW clearly and conspicuously when the ship's shaft / engine power exceeds the limited shaft / engine power as stated in the Onboard Management Manual (OMM) for SHaPoLi / EPL or in any case of system malfunction.

2.2.3 For EPL for the mechanically controlled engine, the sealing device should either:

- .1 visibly indicate removal of the sealing when the ship's engine power exceeds the limited engine power as stated in the OMM for EPL or in any case of system malfunction; or
- .2 be equipped with other systems such as an alert-monitoring system which can indicate when the ship's engine power exceeds the limited engine power as stated in the OMM for EPL or in any case of system malfunction and recording the use of unlimited mode, verified by the Administration or the RO.

2.2.4 The SHaPoLi / EPL system (or each subsystem) should be tamper-proof.

2.2.5 The SHaPoLi / EPL system for the electronically controlled engine should indicate the following data during operation:

- .1 for SHaPoLi, shaft rotational speed, shaft torque and shaft power (and total shaft power in case of multiple shaft arrangements) to be recorded constantly in unlimiting mode; or
- .2 for EPL, a fuel index sealing system or power limitation system which can indicate and record the use of unlimited mode.



2.2.6 The procedure for SHaPoLi / EPL depends on the propulsion system and should be described in the OMM for SHaPoLi / EPL in accordance with section 4 of these Guidelines.

### **3 Use of a power reserve by un-limiting the shaft / engine power limitation**

3.1 The use of a power reserve is only allowed for the purpose of securing the safety of a ship or saving life at sea, consistent with regulation 3.1 of MARPOL Annex VI (e.g. operating in adverse weather and ice-infested waters, participation in search and rescue operations, avoidance of pirates and engine maintenance). Use of a power reserve should not have adverse impact on the propeller, shaft and related systems. It is important that the ship master and OICNW are not restricted from exercising judgement to override the SHaPoLi / EPL when required for safety purposes. The authority for this should be clearly set out in the OMM and/or the Safety Management System manual, as appropriate.

3.2 Any use of a power reserve should be recorded in the record page of the OMM for SHaPoLi / EPL, signed by the master and should be kept on board. The record should include:

- .1 ship type;
- .2 IMO number;
- .3 ship size in DWT and/or GT, as applicable;
- .4 ship's limited shaft / engine power and ship's maximum unlimited shaft / engine power;
- .5 position of the ship and timestamp when the power reserve was used;
- .6 reason for using the power reserve;
- .7 Beaufort number and wave height or ice condition in case of using the power reserve under adverse weather condition;
- .8 supporting evidence (e.g. expected weather condition) in case of using the power reserve for avoidance action;
- .9 records from the SHaPoLi / EPL system for the electronically controlled engine during the power reserve was used; and
- .10 position of the ship and timestamp when the power limit was reactivated or replaced.

3.3 Where an EPL/ShaPoLi override is activated but the power reserve is not subsequently used, this event should be recorded in the bridge and engine-room logbooks. The engine-room logbook should record power used during the period when the override was activated. The EPL/ShaPoLi should be reset as soon as possible, and details of the reset should also be recorded in the bridge and engine-room logbooks.

3.4 In case of having used a power reserve, the ship should without delay notify its Administration or RO responsible for issuing the relevant certificate and the competent authority of the relevant port of destination with the information recorded in accordance with paragraph 3.2. On an annual basis, the Administration should report uses of a power reserve to IMO with the information recorded in accordance with paragraph 3.2.

3.5 Once the risks have been mitigated, the ship should be operated below the certified level of engine power under the SHaPoLi / EPL. The SHaPoLi / EPL system should be reactivated or replaced by the crew immediately after the risks have been prevented and the ship can be safely operated with the limited shaft / engine power. The reactivation or replacement of the SHaPoLi / EPL system should be confirmed (e.g. validation of mechanical sealing) with supporting evidence (e.g. engine power log, photo taken at the occasion of resetting the mechanical sealing) by the Administration or the RO at the earliest opportunity.

3.6 Any defect of the SHaPoLi / EPL system should be reported to the Administration or RO responsible for issuing the relevant certificate in accordance with regulation 5.6 of MARPOL Annex VI.

3.7 The port State control officers should inspect whether the SHaPoLi / EPL system has been properly installed and used in accordance with the IEE Certificate and the OMM as described in section 4 of these Guidelines. If overriding of the SHaPoLi / EPL without proper notification in accordance with paragraph 3.3 of these Guidelines has been detected, the reactivation or replacement of the SHaPoLi / EPL should be immediately conducted in the presence of the Administration or the RO at the port.

#### **4 Onboard Management Manual (OMM) for SHaPoLi / EPL**

4.1 The SHaPoLi / EPL system should be accompanied by the OMM for SHaPoLi / EPL that should be permanently on board the ship for inspection.

4.2 The OMM for SHaPoLi / EPL should be verified by the Administration or the RO after a survey verifying the ship's attained EEXI, as required by regulation 5.4 of MARPOL Annex VI.

4.3 The OMM for SHaPoLi / EPL should, as a minimum, include:

.1 SHaPoLi:

- .1 a technical description of the main system as specified in section 2 of these guidelines as well as relevant auxiliary systems;
- .2 identification of key components of the system by manufacturer, model/type, serial number and other details as necessary;
- .3 description of a verification procedure demonstrating that the system is in compliance with the technical description in accordance with items .1 and .2;
- .4 the maximum shaft power for which the unit is designed;
- .5 service, maintenance and calibration requirements of sensors according to sensor manufacturer and a description how to monitor the appropriateness of the calibration intervals, if applicable;
- .6 the SHaPoLi record book for the recording of service, maintenance and calibration of the system;
- .7 the description how the shaft power can be limited and unlimited and how this is displayed by the control unit as required by paragraph 2.2.5 of these Guidelines;

- .8 the description of how the controller limits the power delivered to the propeller shaft;
  - .9 the identification of responsibilities;
  - .10 procedures for notification of the use of power reserve and the detections of malfunctions of the system in accordance with paragraphs 3.4 and 3.5 of these Guidelines;
  - .11 time required for un-limiting the SHaPoLi; and
  - .12 procedures for survey of the SHaPoLi system by the Administration/RO.
- .2 EPL:
- .1 rated installed power (MCR) or motor output (MPP) and engine speed ( $N_{MCR}$ );
  - .2 limited installed power ( $MCR_{lim}$ ) or motor output ( $MPP_{lim}$ ) and engine speed ( $N_{MCR,lim}$ );
  - .3 technical description of the EPL system;
  - .4 method for sealing the EPL (mechanically controlled engine);
  - .5 method for locking and monitoring the EPL (electronically controlled engine);
  - .6 procedures and methods for releasing the EPL;
  - .7 time required for unlimiting the EPL;
  - .8 procedures for survey of the EPL system by the Administration/RO;
  - .9 procedure for the report on release of the EPL; and
  - .10 administrator of the EPL system.

## **5 Demonstration of compliance of the SHaPoLi / EPL system**

5.1 The demonstration of compliance of the SHaPoLi / EPL system should be verified by an appropriate survey in accordance with regulation 5.4 of MARPOL Annex VI for the verification of the ship's EEXI according to regulation 23. The survey should include the verification and validation of the system by addressing the following items:

- .1 the verification of compliance of the system with the OMM for SHaPoLi / EPL;
- .2 the verification of compliance of the system with the specifications set out in section 2 of these Guidelines; and
- .3 the verification of the OMM for SHaPoLi / EPL that the OMM for SHaPoLi / EPL is in compliance with the specifications set out in section 4 of these Guidelines.

5.2 In cases where the SHaPoLi / EPL system is applied and no changes are made to NO<sub>x</sub> critical settings and/or components\* outside what is allowed by the engine technical file as defined in the 2008 NO<sub>x</sub> Technical Code (NTC 2008), engine re-certification is not needed.

5.3 In cases where the SHaPoLi / EPL system is applied and the NO<sub>x</sub> critical settings and/or components are altered beyond what is allowed by the engine technical file as defined in NTC 2008, the engine needs to be re-certified. In such a case, for an EEDI-certified ship where the SHaPoLi / EPL system is applied at a power below that required by regulation 24.5 of MARPOL Annex VI (minimum power requirement), the certified engine power should be at the power satisfying that requirement.

\*\*\*

---

\* NO<sub>x</sub> critical parameters and components are listed in NO<sub>x</sub> Technical File under the section "Components, setting and operating values of the engine which may influence its NO<sub>x</sub> emission".

**ANNEX 10**

**RESOLUTION MEPC.336(76)  
(adopted on 17 June 2021)**

**2021 GUIDELINES ON OPERATIONAL CARBON INTENSITY INDICATORS AND THE  
CALCULATION METHODS (CII GUIDELINES, G1)**

THE MARINE ENVIRONMENT PROTECTION COMMITTEE,

RECALLING Article 38(a) of the Convention on the International Maritime Organization concerning the functions of the Marine Environment Protection Committee conferred upon it by international conventions for the prevention and control of marine pollution from ships,

NOTING that it adopted, by resolution MEPC.328(76), the 2021 revised MARPOL Annex VI, which is expected to enter into force on 1 November 2022 upon its deemed acceptance on 1 May 2022,

NOTING IN PARTICULAR that the 2021 revised MARPOL Annex VI contains amendments concerning mandatory goal-based technical and operational measures to reduce carbon intensity of international shipping,

NOTING FURTHER that regulation 28.1 of MARPOL Annex VI requires ships to which this regulation apply to calculate the attained annual operational CII taking into account the guidelines developed by the Organization,

RECOGNIZING that the aforementioned amendments to MARPOL Annex VI require relevant guidelines for uniform and effective implementation of the regulations and to provide sufficient lead time for industry to prepare,

HAVING CONSIDERED, at its seventy-sixth session, draft *2021 Guidelines on operational carbon intensity indicators and the calculation methods (CII Guidelines, G1)*,

1 ADOPTS the *2021 Guidelines on operational carbon intensity indicators and the calculation methods (CII Guidelines, G1)*, as set out in the annex to the present resolution;

2 INVITES Administrations to take the annexed Guidelines into account when developing and enacting national laws which give force to and implement requirements set forth in regulation 28.1 of MARPOL Annex VI;

3 REQUESTS the Parties to MARPOL Annex VI and other Member Governments to bring the annexed Guidelines to the attention of masters, seafarers, shipowners, ship operators and any other interested parties;

4 AGREES to consider substantiated proposals for CII correction factors for certain ship types, operational profiles and/or voyages with a view to enhancing, as appropriate, the annexed Guidelines before entry into force of the aforementioned amendments to MARPOL Annex VI;

5 AGREES to keep the Guidelines under review in light of experience gained with their implementation and in light of the review of CII regulations to be completed by the Organization by 1 January 2026 as identified in regulation 28.11 of MARPOL Annex VI.

## ANNEX

### 2021 GUIDELINES ON OPERATIONAL CARBON INTENSITY INDICATORS AND THE CALCULATION METHODS (CII GUIDELINES, G1)

#### 1 Introduction

1.1 In the *Initial IMO Strategy on Reduction of GHG Emissions from Ships* (Resolution MEPC.304(72)), the level of ambition on carbon intensity of international shipping is quantified by the CO<sub>2</sub> emissions per transport work, as an average across international shipping.

1.2 These Guidelines address the calculation methods and the applicability of the operational carbon intensity indicator (CII) for individual ships to which chapter 4 of MARPOL Annex VI, as amended, applies.

#### 2 Definitions

2.1 *MARPOL* means the International Convention for the Prevention of Pollution from Ships, 1973, as modified by the Protocols of 1978 and 1997 relating thereto, as amended.

2.2 *IMO DCS* means the data collection system for fuel oil consumption of ships referred to in regulation 27 and related provisions of MARPOL Annex VI.

2.3 For the purpose of these Guidelines, the definitions in MARPOL Annex VI, as amended, apply.

2.4 The metrics indicating the average CO<sub>2</sub> emissions per transport work of a ship are generally referred to as operational carbon intensity indicator (CII) in these Guidelines.

.1 A specific CII calculated based on the actual or estimated mass or volume of the shipment carried on board a ship is generally referred to as *demand-based CII*; and

.2 A specific CII, in which calculation the capacity of a ship is taken as proxy of the actual mass or volume of the shipment carried on board, is generally referred to as *supply-based CII*.

2.5 The supply-based CII which uses DWT as the capacity is referred to as *AER*, and the supply-based CII which uses GT as the capacity is referred to as *cgDIST*.

#### 3 Application

3.1 For all ships to which regulation 28 of MARPOL Annex VI applies, the operational carbon intensity indicators defined in section 4 should be applied.

3.2 The operational carbon intensity indicators defined in section 5 are encouraged to be additionally used by ships, where applicable, for trial purposes.

#### 4 Operational carbon intensity indicator (CII) of individual ships for use in implementing regulation 28 of MARPOL Annex VI

In its most simple form, the attained annual operational CII of individual ships is calculated as the ratio of the total mass of CO<sub>2</sub> ( $M$ ) emitted to the total transport work ( $W$ ) undertaken in a given calendar year, as follows:

$$\text{attained } CII_{\text{ship}} = M / W \quad (1)$$

##### 4.1 Mass of CO<sub>2</sub> emissions ( $M$ )

The total mass of CO<sub>2</sub> is the sum of CO<sub>2</sub> emissions (in grams) from all the fuel oil consumed on board a ship in a given calendar year, as follows:

$$M = FC_j \times C_{F_j} \quad (2)$$

where:

- $J$  is the fuel oil type;
- $FC_j$  is the total mass (in grams) of consumed fuel oil of type  $J$  in the calendar year, as reported under IMO DCS; and
- $C_{F_j}$  represents the fuel oil mass to CO<sub>2</sub> mass conversion factor for fuel oil type  $J$ , in line with those specified in the *2018 Guidelines on the method of calculation of the attained Energy Efficiency Design Index (EEDI) for new ships (resolution MEPC.308(73))*, as may be further amended. In case the type of the fuel oil is not covered by the guidelines, the conversion factor should be obtained from the fuel oil supplier supported by documentary evidence.

##### 4.2 Transport work ( $W$ )

In the absence of the data on actual transport work, the supply-based transport work ( $W_s$ ) can be taken as a proxy, which is defined as the product of a ship's capacity and the distance travelled in a given calendar year, as follows:

$$W_s = C \times D_t \quad (3)$$

where:

- $C$  represents the ship's capacity:
  - For bulk carriers, tankers, container ships, gas carriers, LNG carriers, ro-ro cargo ships, general cargo ships, refrigerated cargo carrier and combination carriers, deadweight tonnage (DWT)<sup>1</sup> should be used as Capacity;
  - For cruise passenger ships, ro-ro cargo ships (vehicle carriers) and ro-ro passenger ships, gross tonnage (GT)<sup>2</sup> should be used as Capacity; and
- $D_t$  represents the total distance travelled (in nautical miles), as reported under IMO DCS.

<sup>1</sup> Deadweight tonnage (DWT) means the difference in tonnes between the displacement of a ship in water of relative density of 1,025 kg/m<sup>3</sup> at the summer load draught and the lightweight of the ship. The summer load draught should be taken as the maximum summer draught as certified in the stability booklet approved by the Administration or any organization recognized by it.

<sup>2</sup> Gross tonnage (GT) should be calculated in accordance with the International Convention on Tonnage Measurement of Ships, 1969.

## 5 Operational carbon intensity indicator (CII) of individual ships for trial purpose

The following metrics are encouraged to be used for trial purposes, where applicable:

- .1 Energy Efficiency Performance Indicator (EEPI)

$$EEPI = \frac{M}{C \times D_l}$$

- .2 cbDIST

$$cbDIST = \frac{M}{ALB \times D_t}$$

- .3 clDIST

$$clDIST = \frac{M}{Lanemeter \times D_t}$$

- .4 EEOI, as defined in MEPC.1/Circ.684 on *Guidelines for voluntary use of the ship energy efficiency operational indicator (EEOI)*.

In the formulas above:

- the mass of CO<sub>2</sub> ( $M$ ), the ship's capacity ( $C$ ) and the total distance travelled ( $D_t$ ) are identical with those used to calculate the attained CII of individual ships, as specified in section 4.1 and 4.2;
- $D_l$  means the laden distance travelled (in nautical miles) when the ship is loaded;
- $ALB$  means the number of available lower berths of a cruise passenger ship; and
- $Lanemeter$  means the length (in metres) of the lanes of a ro-ro ship.

\*\*\*



**ANNEX 11**

**RESOLUTION MEPC.337(76)  
(adopted on 17 June 2021)**

**2021 GUIDELINES ON THE REFERENCE LINES FOR USE WITH OPERATIONAL  
CARBON INTENSITY INDICATORS (CII REFERENCE LINES GUIDELINES, G2)**

THE MARINE ENVIRONMENT PROTECTION COMMITTEE,

RECALLING Article 38(a) of the Convention on the International Maritime Organization concerning the functions of the Marine Environment Protection Committee conferred upon it by international conventions for the prevention and control of marine pollution from ships,

NOTING that it adopted, by resolution MEPC.328(76), the 2021 revised MARPOL Annex VI, which is expected to enter into force on 1 November 2022 upon its deemed acceptance on 1 May 2022,

NOTING IN PARTICULAR that the 2021 revised MARPOL Annex VI contains amendments concerning mandatory goal-based technical and operational measures to reduce carbon intensity of international shipping,

NOTING FURTHER that regulation 28.4 of MARPOL Annex VI requires reference lines to be established for each ship type to which regulation 28 is applicable,

HAVING CONSIDERED, at its seventy-sixth session, draft *2021 Guidelines on the reference lines for use with operational carbon intensity indicators (CII reference lines guidelines, G2)*,

1 ADOPTS the *2021 Guidelines on the reference lines for use with operational carbon intensity indicators (CII reference lines guidelines, G2)*, as set out in the annex to the present resolution;

2 INVITES Administrations to take the annexed Guidelines into account when developing and enacting national laws which give force to and implement requirements set forth in regulation 28.4 of MARPOL Annex VI;

3 REQUESTS the Parties to MARPOL Annex VI and other Member Governments to bring the annexed Guidelines to the attention of masters, seafarers, shipowners, ship operators and any other interested parties;

4 AGREES to keep the Guidelines under review in light of experience gained with their implementation and in light of the review of CII regulations to be completed by the Organization by 1 January 2026 as identified in regulation 28.11 of MARPOL Annex VI.

## ANNEX

### 2021 GUIDELINES ON THE REFERENCE LINES FOR USE WITH OPERATIONAL CARBON INTENSITY INDICATORS (CII REFERENCE LINES GUIDELINES, G2)

#### 1 Introduction

1.1 These Guidelines provide the methods to calculate the reference lines for use with operational carbon intensity indicators, and the ship type specific carbon intensity reference lines as referred to in regulation 28 of MARPOL Annex VI.

1.2 One reference line is developed for each ship type to which regulation 28 of MARPOL Annex VI applies, based on the specific indicators stipulated in *2021 Guidelines on operational carbon intensity indicators and the calculation methods* (G1) developed by the Organization, ensuring that only data from comparable ships are included in the calculation of each reference line.

#### 2 Definition

2.1 *MARPOL* means the International Convention for the Prevention of Pollution from Ships, 1973, as modified by the Protocols of 1978 and 1997 relating thereto, as amended.

2.2 *IMO DCS* means the data collection system for fuel oil consumption of ships referred to in regulation 27 and related provisions of MARPOL Annex VI.

2.3 For the purpose of these Guidelines, the definitions in MARPOL Annex VI, as amended, apply.

2.4 An operational carbon intensity indicator (CII) reference line is defined as a curve representing the median attained operational carbon intensity performance, as a function of Capacity, of a defined group of ships in year of 2019.

#### 3 Method to develop the CII reference lines

3.1 Given the limited data available for the year of 2008, the operational carbon intensity performance of ship types in year 2019 is taken as the reference.

3.2 For a defined group of ships, the reference line is formulated as follows:

$$CII_{ref} = aCapacity^{-c} \quad (1)$$

where  $CII_{ref}$  is the reference value of year 2019,  $Capacity$  is identical with the one defined in the specific carbon intensity indicator (CII) for a ship type, as shown in Table. 1;  $a$  and  $c$  are parameters estimated through median regression fits, taking the attained CII and the Capacity of individual ships collected through IMO DCS in year 2019 as the sample.

#### 4 Ship type specific operational carbon intensity reference lines

The parameters for determining the ship type specific reference lines, for use in Eq.(1), are specified as follows:

**Table 1: Parameters for determining the 2019 ship type specific reference lines**

Ship type		Capacity	<i>a</i>	<i>c</i>
Bulk carrier	279,000 DWT and above	279,000	4745	0.622
	less than 279,000 DWT	DWT	4745	0.622
Gas carrier	65,000 and above	DWT	14405E7	2.071
	less than 65,000 DWT	DWT	8104	0.639
Tanker		DWT	5247	0.610
Container ship		DWT	1984	0.489
General cargo ship	20,000 DWT and above	DWT	31948	0.792
	less than 20,000 DWT	DWT	588	0.3885
Refrigerated cargo carrier		DWT	4600	0.557
Combination carrier		DWT	40853	0.812
LNG carrier	100,000 DWT and above	DWT	9.827	0.000
	65,000 DWT and above, but less than 100,000 DWT	DWT	14479E10	2.673
	less than 65,000 DWT	65,000	14479E10	2.673
Ro-ro cargo ship (vehicle carrier)		GT	5739	0.631
Ro-ro cargo ship		DWT	10952	0.637
Ro-ro passenger ship		GT	7540	0.587
Cruise passenger ship		GT	930	0.383

\*\*\*



**ANNEX 12**

**RESOLUTION MEPC.338(76)  
(adopted on 17 June 2021)**

**2021 GUIDELINES ON THE OPERATIONAL CARBON INTENSITY REDUCTION  
FACTORS RELATIVE TO REFERENCE LINES (CII REDUCTION  
FACTORS GUIDELINES, G3)**

THE MARINE ENVIRONMENT PROTECTION COMMITTEE,

RECALLING Article 38(a) of the Convention on the International Maritime Organization concerning the functions of the Marine Environment Protection Committee conferred upon it by international conventions for the prevention and control of marine pollution from ships,

NOTING that it adopted, by resolution MEPC.328(76), the 2021 revised MARPOL Annex VI, which is expected to enter into force on 1 November 2022 upon its deemed acceptance on 1 May 2022,

NOTING IN PARTICULAR that the 2021 revised MARPOL Annex VI contains amendments concerning mandatory goal-based technical and operational measures to reduce carbon intensity of international shipping,

NOTING FURTHER that regulation 28.4 of MARPOL Annex VI requires reduction factors to be established for each ship type to which regulation 28 is applicable,

HAVING CONSIDERED, at its seventy-sixth session, draft *2021 Guidelines on the operational carbon intensity reduction factors relative to reference lines (CII reduction factors guidelines, G3)*,

1 ADOPTS the *2021 Guidelines on the operational carbon intensity reduction factors relative to reference lines (CII reduction factors guidelines, G3)*, as set out in the annex to the present resolution;

2 INVITES Administrations to take the annexed Guidelines into account when developing and enacting national laws which give force to and implement requirements set forth in regulation 28.4 of MARPOL Annex VI;

3 REQUESTS the Parties to MARPOL Annex VI and other Member Governments to bring the annexed Guidelines to the attention of masters, seafarers, shipowners, ship operators and any other interested parties;

4 AGREES to keep the Guidelines under review in light of experience gained with their implementation and in light of the review of CII regulations to be completed by the Organization by 1 January 2026 as identified in regulation 28.11 of MARPOL Annex VI, and that annual reduction rates for the period 2027-2030 will be further strengthened and developed taking into account that review.

## ANNEX

### **2021 GUIDELINES ON THE OPERATIONAL CARBON INTENSITY REDUCTION FACTORS RELATIVE TO REFERENCE LINES (CII REDUCTION FACTORS GUIDELINES, G3)**

#### **1 Introduction**

1.1 These Guidelines provide the methods to determine the annual operational carbon intensity reduction factors and their concrete values from year 2023 to 2030, as referred to in regulation 28 of MARPOL Annex VI.

1.2 The annual operational carbon intensity reduction factors apply to each ship type to which regulation 28 of MARPOL Annex VI applies, in a transparent and robust manner, based on the specific carbon intensity indicators stipulated in the *2021 Guidelines on operational carbon intensity indicators and the calculation methods (G1)* (resolution MEPC.336(76)) and the reference lines developed in the *2021 Guidelines on the reference lines for use with operational carbon intensity indicators (G2)*(resolution MEPC.337(76)).

1.3 The reduction factors have been set at the levels to ensure that, in combination with other relevant requirements of MARPOL Annex VI, the reduction in CO<sub>2</sub> emissions per transport work by at least 40% by 2030, compared to 2008, can be achieved as an average across international shipping.

1.4 Section 5 of these Guidelines provides background information on rational ranges of reduction factors of ship types in year 2030 using demand-based measurement and supply-based measurement.

1.5 The Organization should continue to monitor development in annual carbon intensity improvement using both demand-based measurement and supply-based measurement in parallel to the annual analysis of the fuel consumption data reported to the IMO DCS.

#### **2 Definitions**

2.1 *MARPOL* means the International Convention for the Prevention of Pollution from Ships, 1973, as modified by the Protocols of 1978 and 1997 relating thereto, as amended.

2.2 *IMO DCS* means the data collection system for fuel oil consumption of ships referred to in regulation 27 and related provisions of MARPOL Annex VI.

2.3 For the purpose of these Guidelines, the definitions in MARPOL Annex VI, as amended, apply.

2.4 The annual operational carbon intensity reduction factor, generally denoted as "Z" in regulation 28 of MARPOL Annex VI, is a positive value, stipulating the percentage points of the required annual operational carbon intensity indicator of a ship for a given year lower than the reference value.

### 3 Method to determine the annual reduction factor of ship types

#### 3.1 Operational carbon intensity of international shipping

Given significant heterogeneity across ship types, the attained annual operational CII of international shipping as a whole is calculated as the ratio of the aggregated mass (in grams) of CO<sub>2</sub> (*aggregated M*) emitted to the aggregated mass (in tonne·nmiles) of transport work (*aggregated W*) undertaken by all individual ships of representative ship types in a given calendar year, as follows:

$$\text{attained } CII_{shipping} = \text{aggregated } M / \text{aggregated } W \quad (1)$$

In the absence of the data on actual annual transport work of individual ships, the aggregated transport work obtained from other reliable sources, such as UNCTAD, can be taken as approximation. The representative ship types refer to bulk carriers, gas carriers, tankers, container ships, general cargo ships, refrigerated cargo carrier and LNG carriers, as per the *Fourth IMO GHG Study 2020*.

#### 3.2 The achieved carbon intensity reduction in international shipping

For a given year  $y$ , the achieved carbon intensity reduction in international shipping relative to the reference year  $y_{ref}$ , denoted as  $R_{shipping,y}$ , can be calculated as follows:

$$R_{shipping,y} = 100\% \times (\text{attained } CII_{shipping,y} - \text{attained } CII_{shipping,y_{ref}}) / \text{attained } CII_{shipping,y_{ref}} \quad (2)$$

where the  $\text{attained } CII_{shipping,y}$  and  $\text{attained } CII_{shipping,y_{ref}}$  represents the attained annual operational carbon intensity of international shipping in year  $y$  and in the reference year  $y_{ref}$ , as defined in Eq.(1).

The achieved carbon intensity reduction in international shipping can be alternatively calculated on the carbon intensity performance of ship types. Since CII metrics for different ship types may not be identical, the weighted average of the carbon intensity reduction achieved by ship types can be applied, as follows:

$$R_{shipping,y} = \sum_{type} f_{type,y} R_{type,y} \quad (3)$$

In Eq(3),

- $type$  represents the ship type;
- $f_{type,y}$  is the weight, which is equal to the proportion of CO<sub>2</sub> emitted by the ship type to the total CO<sub>2</sub> emissions of international shipping in year  $y$ ; and
- $R_{type,y}$  represents the carbon intensity reduction achieved by the ship type in year  $y$ , calculated as  $R_{type,y} = 100\% \times (\text{attained } CII_{type,y} - \text{attained } CII_{type,y_{ref}}) / \text{attained } CII_{type,y_{ref}}$ , where the  $\text{attained } CII_{type,y}$  and  $\text{attained } CII_{type,y_{ref}}$  represents the attained annual operational carbon intensity of the ship type in year  $y$  and in the reference year  $y_{ref}$ , as defined in Eq.(4), as follows:

$$\text{attained } CII_{type} = \sum_{ship} M_{ship,t} / \sum_{ship} W_{ship,t} \quad (4)$$

where:

$M_{ship,t}$  and  $W_{ship,t}$  represents the total mass of CO<sub>2</sub> emitted from and the total transport work undertaken by a ship of this type in a given calendar year, as stipulated in the *Guidelines on operational carbon intensity indicators and the calculation methods (G1)*.

#### 4 The reduction factors for the required annual operational CII of ship types

4.1 In accordance with regulation 28 of MARPOL Annex VI, the required annual operational CII for a ship is calculated as follows:

$$\text{Required annual operational CII} = (1 - Z / 100) \times CII_R$$

where  $CII_R$  is the reference value in year 2019 as defined in the *Guidelines on the reference lines for use with operational carbon intensity indicators (G2)*,  $Z$  is a general reference to the reduction factors for the required annual operational CII of ship types from year 2023 to 2030, as specified in table 1.

**Table 1: Reduction factor (Z%) for the CII relative to the 2019 reference line**

Year	Reduction factor relative to 2019
2023	5%*
2024	7%
2025	9%
2026	11%
2027	- **
2028	- **
2029	- **
2030	- **

Note:

- \* Z factors of 1%, 2% and 3% are set for the years of 2020 to 2022, similar as business as usual until entry into force of the measure.
- \*\* Z factors for the years of 2027 to 2030 to be further strengthened and developed taking into account the review of the short-term measure.



## 5 Background information on rational ranges of reduction factors of ship types in year 2030

5.1 In the *Initial IMO Strategy on Reduction of GHG Emissions from Ships* (Resolution MEPC.304(72)), the levels of ambition on carbon intensity of international shipping have been set taking year 2008 as reference. The carbon intensity of international shipping in year 2008, as well as the improvement through 2012 to 2018, has been estimated in the *Fourth IMO GHG Study 2020*. However, since the scope and data collection methods applied in the *Fourth IMO GHG Study 2020* were inconsistent with those under IMO DCS, the results derived from the two sources cannot be compared directly.

5.2 To ensure the comparability of the attained carbon intensity of international shipping through year 2023 to 2030 with the reference line, the following methods are applied to calculate the equivalent carbon intensity target in year 2030 ( $eR_{shipping,2030}$ ), taking year 2019 as reference, i.e. how much additional improvement is needed by 2030 from the 2019 performance level.

5.3 The achieved carbon intensity reduction of international shipping in year 2019 relative to year 2008 ( $R_{shipping,2019}$ ) can be estimated as the sum of the achieved carbon intensity reduction of international shipping in year 2018 relative to year 2008 ( $R_{shipping,2018}$ ) as given by the *Fourth IMO GHG Study 2020* and the estimated average annual improvement during 2012 and 2018 ( $\bar{r}_{shipping}$ ), as follows:

$$R_{shipping,2019} = R_{shipping,2018} + \bar{r}_{shipping} \quad (5)$$

5.4 The following provides the calculations using demand-based measurement and supply-based measurement.

### 5.4.1 Demand-based measurement of 2030 target

As estimated by the *Fourth IMO GHG Study 2020*, the attained CII of international shipping (on aggregated demand-based metric) has reduced by **31.8%** ( $R_{shipping,2018} = 31.8\%$ ) compared to 2008, with an estimated average annual improvement at **1.5** percentage points ( $\bar{r}_{shipping} = 1.5\%$ ). In accordance with Eq.(5), the carbon intensity reduction achieved in year 2019 is estimated as **33.3%** ( $R_{shipping,2019} = 33.3\%$ ).

### 5.4.2 Supply-based measurement of 2030 target

As estimated by the *Fourth IMO GHG Study 2020*, the attained CII of international shipping (on aggregated supply-based metric) has reduced by **22.0%** ( $R_{shipping,2018} = 22.0\%$ ) compared to 2008, with an estimated average annual improvement at **1.6** percentage points ( $\bar{r}_{shipping} = 1.6\%$ ). In accordance with Eq.(5), the carbon intensity reduction achieved in year 2019 relative to 2008 is estimated as **23.6%** ( $R_{shipping,2019} = 23.6\%$ ).

5.5 Given the achieved carbon intensity reduction of international shipping in year 2019 relative to year 2008, the carbon intensity reduction target of international shipping in year 2030 can be converted to the equivalent target ( $eR_{shipping,2030}$ ) relative to year 2019, as follows:

$$eR_{shipping,2030} = \frac{40\% - R_{shipping,2019}}{1 - R_{shipping,2019}} \quad (6)$$

#### *5.5.1 Demand-based measurement of 2030 target*

In accordance with Eq.(6), the equivalent reduction factor of international shipping in year 2030 relative to year 2019 (  $eR_{shipping,2030}$  ) would be at least **10.0%** measured in aggregated demand-based CII metric, i.e. at least additional **10.0%** improvement from the 2019 level is needed by 2030.

#### *5.5.2 Supply-based measurement of 2030 target*

In accordance with Eq.(6), the equivalent reduction factor of international shipping in 2030 relative to year 2019 (  $eR_{shipping,2030}$  ) would be at least **21.5%**, measured in aggregated supply-based CII metric, i.e. at least additional **21.5%** improvement from the 2019 level is needed by 2030.

\*\*\*

**ANNEX 13**

**RESOLUTION MEPC.339(76)  
(adopted on 17 June 2021)**

**2021 GUIDELINES ON THE OPERATIONAL CARBON INTENSITY  
RATING OF SHIPS (CII RATING GUIDELINES, G4)**

THE MARINE ENVIRONMENT PROTECTION COMMITTEE,

RECALLING Article 38(a) of the Convention on the International Maritime Organization concerning the functions of the Marine Environment Protection Committee conferred upon it by international conventions for the prevention and control of marine pollution from ships,

NOTING that it adopted, by resolution MEPC.328(76), the 2021 revised MARPOL Annex VI, which is expected to enter into force on 1 November 2022 upon its deemed acceptance on 1 May 2022,

NOTING IN PARTICULAR that the 2021 revised MARPOL Annex VI contains amendments concerning mandatory goal-based technical and operational measures to reduce carbon intensity of international shipping,

NOTING FURTHER that regulation 28.6 of MARPOL Annex VI requires ships to which this regulation apply to determine operational carbon intensity rating taking into account guidelines developed by the Organization,

RECOGNIZING that the aforementioned amendments to MARPOL Annex VI require relevant guidelines for uniform and effective implementation of the regulations,

HAVING CONSIDERED, at its seventy-sixth session, draft *2021 Guidelines on the operational carbon intensity rating of ships (CII rating guidelines, G4)*,

1 ADOPTS the *2021 Guidelines on the operational carbon intensity rating of ships (CII rating guidelines, G4)*, as set out in the annex to the present resolution;

2 INVITES Administrations to take the annexed Guidelines into account when developing and enacting national laws which give force to and implement requirements set forth in regulation 28.6 of MARPOL Annex VI;

3 REQUESTS the Parties to MARPOL Annex VI and other Member Governments to bring the annexed Guidelines to the attention of masters, seafarers, shipowners, ship operators and any other interested parties;

4 AGREES to keep the Guidelines under review in light of experience gained with their implementation, of additional data collected and analysed, and in light of the review of CII regulations to be completed by the Organization by 1 January 2026 as identified in regulation 28.11 of MARPOL Annex VI.

## ANNEX

### 2021 GUIDELINES ON THE OPERATIONAL CARBON INTENSITY RATING OF SHIPS (CII RATING GUIDELINES, G4)

#### 1 Introduction

1.1 These Guidelines provide the methods to assign operational energy efficiency performance ratings to ships, as referred to in regulation 28 of MARPOL Annex VI. On this basis, the boundaries for determining a ship's annual operational carbon intensity performance from year 2023 to 2030 are also provided.

#### 2 Definitions

2.1 *MARPOL* means the International Convention for the Prevention of Pollution from Ships, 1973, as modified by the Protocols of 1978 and 1997 relating thereto, as amended.

2.2 *IMO DCS* means the data collection system for fuel oil consumption of ships referred to in regulation 28 and related provisions of MARPOL Annex VI.

2.3 For the purpose of these Guidelines, the definitions in MARPOL Annex VI, as amended, apply.

2.4 *Operational carbon intensity rating* means to assign a ranking label from among the five grades (A, B, C, D and E) to the ship based on the attained annual operational carbon intensity indicator, indicating a major superior, minor superior, moderate, minor inferior, or inferior performance level.

#### 3 Framework of the operational energy efficiency performance rating

3.1 An operational energy efficiency performance rating should be annually assigned to each ship to which regulation 28 of MARPOL Annex VI applies, in a transparent and robust manner, based on the deviation of the attained annual operational carbon intensity indicator (CII) of a ship from the required value.

3.2 To facilitate the rating assignment, for each year from 2023 to 2030, four boundaries are defined for the five-grade rating mechanism, namely superior boundary, lower boundary, upper boundary, and inferior boundary. Thus, a rating can be assigned through comparing the attained annual operational CII of a ship with the boundary values.

3.3 The boundaries are set based on the distribution of CIIs of individual ships in year 2019. The appropriate rating boundaries are expected to generate the following results: the middle 30% of individual ships across the fleet segment, in terms of the attained annual operational CIIs, are to be assigned rating C, while the upper 20% and further upper 15% of individuals are to be assigned rating D and E respectively, the lower 20% and further lower 15% of the individuals are to be assigned rating B and A respectively, as illustrated in figure 1.

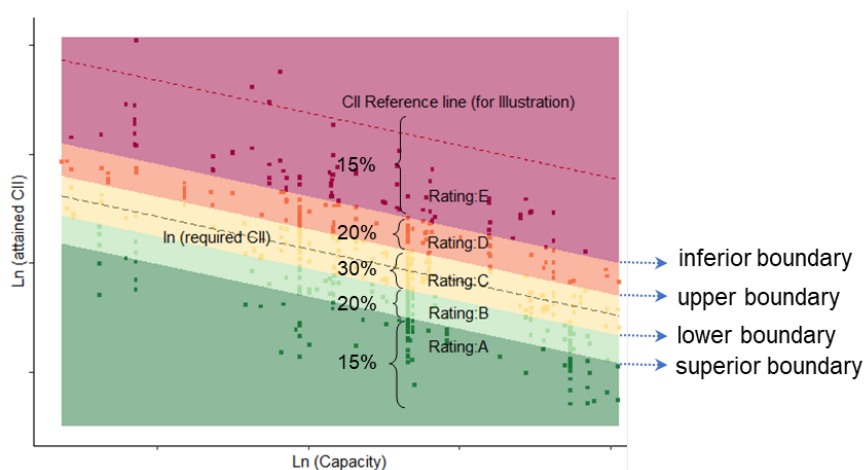
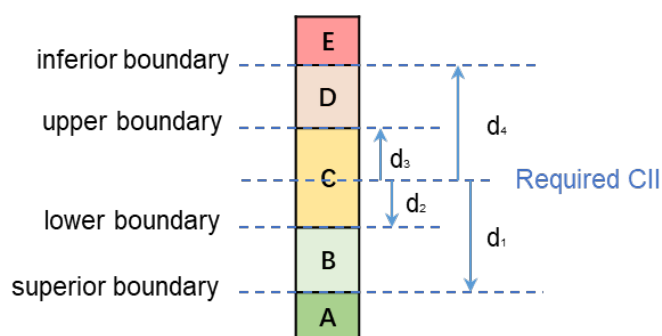

**Figure 1: Operational energy efficiency performance rating scale**

3.4 Given the incremental operational carbon intensity reduction factors over time, the boundaries for defining performance ratings should be synchronized accordingly, although the relative distance between the boundaries should not change. The rating of a ship would be determined by the attained CII and the predetermined rating boundaries, rather than the attained CII of other ships. Note that the distribution of ship individual ratings in a specific year may not be always identical with the scenario in 2019, where for example 20% may achieve A, 30% may achieve B, 40% may achieve C, 8% may achieve D and 2% may achieve E in a given year.

#### 4 Method to determine the rating boundaries

4.1 The boundaries can be determined by the required annual operational CII in conjunction with the vectors, indicating the direction and distance they deviate from the required value (denoted as  $dd$  vectors for easy reference), as illustrated in figure 2.



**Figure 2:  $dd$  vectors and rating bands**

4.2 Statistically, the  $dd$  vectors depend on the distribution of the attained annual operational CII of ships of the type concerned, which can be estimated through a quantile regression, taking data collected through DCS in year 2019 as the sample.

4.3 The quantile regression model for a specific ship type can be developed as follows:

$$\ln(\text{attained CII}) = \delta^{(p)} - c \ln(\text{Capacity}) + \varepsilon^{(p)}, \quad p = \{0.15, 0.35, 0.50, 0.65, 0.85\} \quad (5)$$

where  $Capacity$  is identical with the one used in the operation carbon intensity indicator as specified in the Guidelines on operational carbon intensity indicators and the calculation

methods (G1);  $p$  is the typical quantile, meaning the proportion of observations with a lower value is  $p\%$ ;  $\delta^{(p)}$  is the constant term, and  $\varepsilon^{(p)}$  is the error term.

4.4 The quantile regression lines in logarithm form are illustrated in Fig.3.

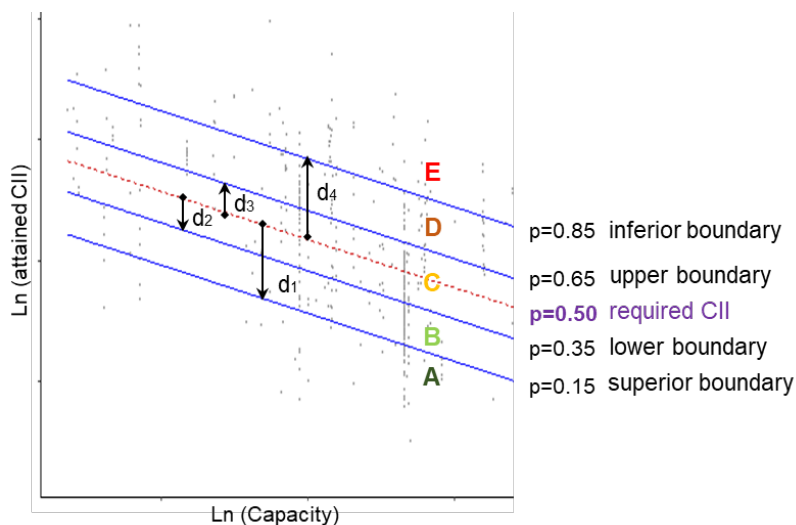

**Figure 3: Quantile regression lines in logarithm form**

4.5 Then, the  $dd$  vectors can be calculated based on the estimates of the intercept ( $\hat{\delta}^{(p)}$ ), in accordance with Eq.(2), as follows:

$$\left. \begin{aligned} d_1 &= \hat{\delta}^{(0.15)} - \hat{\delta}^{(0.50)} \\ d_2 &= \hat{\delta}^{(0.35)} - \hat{\delta}^{(0.50)} \\ d_3 &= \hat{\delta}^{(0.65)} - \hat{\delta}^{(0.50)} \\ d_4 &= \hat{\delta}^{(0.85)} - \hat{\delta}^{(0.50)} \end{aligned} \right\} \quad (6)$$

4.6 Through an exponential transformation of each  $dd$  vector, the four boundaries fitted in the original data form can be derived based on the required annual operational carbon intensity indicator ( $required\ CII$ ), as follows:

$$\left. \begin{aligned} \text{superior boundary} &= \exp(d_1) \cdot \text{required } CII \\ \text{lower boundary} &= \exp(d_2) \cdot \text{required } CII \\ \text{upper boundary} &= \exp(d_3) \cdot \text{required } CII \\ \text{inferior boundary} &= \exp(d_4) \cdot \text{required } CII \end{aligned} \right\} \quad (7)$$

### Rating boundaries of ship types

The estimated  $dd$  vectors after exponential transformation for determining the rating boundaries of ship types are as follows:

**Table 1: *dd* vectors for determining the rating boundaries of ship types**

Ship type		Capacity in CII calculation	<i>dd</i> vectors (after exponential transformation)			
			exp(d1)	exp(d2)	exp(d3)	exp(d4)
Bulk carrier		DWT	0.86	0.94	1.06	1.18
Gas carrier	65,000 DWT and above	DWT	0.81	0.91	1.12	1.44
	less than 65,000 DWT	DWT	0.85	0.95	1.06	1.25
Tanker		DWT	0.82	0.93	1.08	1.28
Container ship		DWT	0.83	0.94	1.07	1.19
General cargo ship		DWT	0.83	0.94	1.06	1.19
Refrigerated cargo carrier		DWT	0.78	0.91	1.07	1.20
Combination carrier		DWT	0.87	0.96	1.06	1.14
LNG carrier	100,000 DWT and above	DWT	0.89	0.98	1.06	1.13
	less than 100,000 DWT		0.78	0.92	1.10	1.37
Ro-ro cargo ship (vehicle carrier)		GT	0.86	0.94	1.06	1.16
Ro-ro cargo ship		DWT	0.66	0.90	1.11	1.37
Ro-ro passenger ship		GT	0.72	0.90	1.12	1.41
Cruise passenger ship		GT	0.87	0.95	1.06	1.16

By comparing the attained annual operational CII of a specific ship with the four boundaries, a rating can then be assigned. For example, given the required CII of a bulk carrier in a specific year as 10 gCO<sub>2</sub>/(dwt.nmile), then the superior boundary, lower boundary, upper boundary, and inferior boundary is 8.6, 9.4, 10.6 and 11.8 gCO<sub>2</sub>/(dwt.nmile). If the attained CII is 9 gCO<sub>2</sub>/(dwt.nmile), the ship would be rated as "B".

\*\*\*