

**INTERNATIONAL MARITIME ORGANIZATION**  
4 ALBERT EMBANKMENT  
LONDON SE1 7SR

Telephone: 020 7735 7611  
Fax: 020 7587 3210  
Telex: 23588 IMOLDN G



*E*

Ref. T2/8.02

SN/Circ.227  
6 January 2003

**GUIDELINES FOR THE INSTALLATION OF A SHIPBORNE  
AUTOMATIC IDENTIFICATION SYSTEM (AIS)**

1 The Sub-Committee on Safety of Navigation (NAV), at its forty-eighth session (8 to 12 July 2002), agreed on guidelines for the installation of a Shipborne Automatic Identification System (AIS) and also agreed that they should be issued for use on a voluntary basis. The Guidelines describe the shipborne AIS installation matters and are meant to be used by manufacturers, installers and surveyors to ensure good installation practices.

2 The Maritime Safety Committee, at its seventy-sixth session (2 to 13 December 2002), concurred with the Sub-Committee's views, approved the Guidelines as set out at annex and encouraged their use for AIS installation purposes on a voluntary basis.

3 Member Governments are invited to bring the annexed guidelines to the attention of all concerned.

\*\*\*



## ANNEX

**GUIDELINES FOR THE INSTALLATION OF A SHIPBORNE  
AUTOMATIC IDENTIFICATION SYSTEM (AIS)**

<b>1</b>	<b><i>General</i></b> .....	<b>2</b>
<b>1.1</b>	<b>Survey</b> .....	<b>2</b>
<b>1.2</b>	<b>Documentation</b> .....	<b>2</b>
<b>2</b>	<b><i>AIS Installation</i></b> .....	<b>3</b>
<b>2.1</b>	<b>Interference to the Ship's VHF Radiotelephone</b> .....	<b>3</b>
<b>2.2</b>	<b>VHF Antenna Installation</b> .....	<b>3</b>
<b>2.3</b>	<b>GNSS Antenna installation</b> .....	<b>4</b>
<b>2.4</b>	<b>Power source</b> .....	<b>5</b>
<b>2.5</b>	<b>Synchronization</b> .....	<b>5</b>
<b>3</b>	<b><i>Bridge Arrangement</i></b> .....	<b>5</b>
<b>3.1</b>	<b>Minimum Keyboard and Display</b> .....	<b>5</b>
<b>3.2</b>	<b>Pilot plug</b> .....	<b>5</b>
<b>3.3</b>	<b>Display system</b> .....	<b>5</b>
<b>3.4</b>	<b>Installation of the BIIT (Built-in Integrity Test) function</b> .....	<b>5</b>
<b>4</b>	<b><i>Dynamic data input</i></b> .....	<b>6</b>
<b>4.1</b>	<b>External Sensors</b> .....	<b>6</b>
<b>4.2</b>	<b>Position, COG and SOG</b> .....	<b>6</b>
<b>4.3</b>	<b>Heading</b> .....	<b>6</b>
<b>4.4</b>	<b>Rate of Turn</b> .....	<b>6</b>
<b>4.5</b>	<b>Navigational Status</b> .....	<b>7</b>
<b>5</b>	<b><i>Static Information</i></b> .....	<b>7</b>
<b>5.1</b>	<b>Entered at initial installation of AIS</b> .....	<b>7</b>
<b>5.2</b>	<b>Reference point of position</b> .....	<b>7</b>
<b>5.3</b>	<b>Ship's dimensions</b> .....	<b>8</b>
<b>6</b>	<b><i>Long-Range function</i></b> .....	<b>8</b>
<b>Annex 1</b>	<b>Rate of Turn</b> .....	<b>9</b>
<b>Annex 2</b>	<b>Type of ship table</b> .....	<b>11</b>
<b>Annex 3</b>	<b>Recommended IEC 61162 sentences</b> .....	<b>12</b>

## **1 General**

The Automatic Identification System (AIS) Class A is defined by IMO and has been made a carriage requirement by the latest revision of SOLAS chapter V. AIS provides information that may be used for the navigation of the ship. It is therefore essential that the information provided by AIS be reliable.

The AIS itself has been standardised by the International Telecommunications Union (ITU) and the International Electrotechnical Commission (IEC) and is subject to type approval. In order to fulfil the reliability requirements of information exchange, care should be taken to ensure that the AIS is correctly installed.

This document contains guidelines for manufacturers, installers, yards, suppliers and ship surveyors. It does not replace documentation supplied by the manufacturer.

The guidelines take into account the following conventions, regulations, instructions and guidelines:

- IMO resolution MSC.90(73) Annex 7, Adoption of amendments to the International Convention for the Safety of Life at Sea, 1974, as amended.
- IMO resolution MSC.74(69) Annex 3, Recommendation on performance standards for AIS.
- ITU Radio Regulations (RR).
- IEC 60092 (series), Electrical Installations on Ships.
- IEC 60533 Electrical and Electronic Installations in Ships – Electromagnetic Compatibility.

### **1.1 Survey**

Surveys on Convention ships should be carried out in accordance with the rules laid down in resolution A.746(18) "Survey Guidelines under the harmonised system of survey and certification", and "Protocol of 1988 relating to the International Convention for the Safety of Life at Sea, 1974, as amended."

### **1.2 Documentation**

For the AIS installation the following drawings shall be submitted:

- Antenna layout
- AIS arrangement drawing
- Block diagram (interconnection diagram)

An initial installation configuration report should be produced during installation and kept on board.

## **2 AIS Installation**

### **2.1 *Interference to the Ship's VHF Radiotelephone***

The AIS shipborne equipment, like any other shipborne transceiver operating in the VHF maritime band, may cause interference to a ship's VHF radiotelephone. Because AIS is a digital system, this interference may occur as a periodic (e.g. every 20 s) soft clicking sound on a ship's radiotelephone. This affect may become more noticeable when the VHF radiotelephone antenna is located near the AIS VHF antenna and when the radiotelephone is operating on channels near the AIS operating channels (e.g. channels 27, 28 and 86).

Attention should be paid to the location and installation of different antennas in order to obtain the best possible efficiency. Special attention should be paid to the installation of mandatory antennas like the AIS antennas.

### **2.2 *VHF Antenna Installation***

#### **2.2.1 Location**

Location of the mandatory AIS VHF antenna should be carefully considered. Digital communication is more sensitive than analogue/voice communication to interference created by reflections in obstructions like masts and booms. It may be necessary to relocate the VHF radiotelephone antenna to minimize interference effects.

To minimise interference effects, the following guidelines apply:

- The AIS VHF antenna should have omnidirectional vertical polarisation.
- The AIS VHF antenna should be placed in an elevated position that is as free as possible with a minimum of 2 metres in horizontal direction from constructions made of conductive materials. The antenna should not be installed close to any large vertical obstruction. The objective for the AIS VHF antenna is to see the horizon freely through 360°.
- The AIS VHF antenna should be installed safely away from interfering high-power energy sources like radar and other transmitting radio antennas, preferably at least 3 m away from and out of the transmitting beam.
- Ideally there should not be more than one antenna on the same level. The AIS VHF antenna should be mounted directly above or below the ship's primary VHF radiotelephone antenna, with no horizontal separation and with a minimum of 2 m vertical separation. If it is located on the same level as other antennas, the distance apart should be at least 10 m.

#### **2.2.2 Cabling**

The cable should be kept as short as possible to minimise attenuation of the signal. Double screened coaxial cables equal or better than RG214 are recommended.

All outdoor installed connectors on the coaxial cables should be waterproof by design to protect against water penetration into the antenna cable.

Coaxial cables should be installed in separate signal cable channels/tubes and at least 10 cm away from power supply cables. Crossing of cables should be done at right angles (90°). Coaxial cables should not be exposed to sharp bends, which may lead to change the characteristic impedance of the cable. The minimum bend radius should be 5 times the cable's outside diameter.

### **2.2.3 Grounding**

Coaxial down-leads should be used for all antennas, and the coaxial screen should be connected to ground at one end.

## **2.3 GNSS Antenna installation**

Class A AIS should be connected to a GNSS antenna.

### **2.3.1 Location**

The GNSS antenna should be installed where it has a clear view of the sky. The objective is to see the horizon freely through 360° with a vertical observation of 5 to 90° above the horizon. Small diameter obstructions, such as masts and booms, do not seriously degrade signal reception, but such objects should not eclipse more than a few degrees of any given bearing.

Locate the antenna at least three meters away from and out of the transmitting beam of high-power transmitters (S-Band Radar and/or Inmarsat systems). This includes the ship's own AIS VHF antenna if it is designed and installed separately.

If a DGNSS system is included or connected to the AIS system, the installation of the antenna should be in accordance with IEC 61108-4, Ed 1, annex D.

### **2.3.2 Cabling**

To achieve optimum performance, the gain of the antenna pre-amplifier should match the cable attenuation. The resulting installation gain (pre-amplifier gain - cable attenuation) should be within 0 to 10 dB.

The coaxial cable between the antenna and the AIS shipborne station connector should be routed directly in order to reduce electromagnetic interference effects. The cable should not be installed close to high-power lines, such as radar or radio-transmitter lines or the AIS VHF antenna cable. A separation of one meter or more is recommended to avoid degradation due to RF-coupling. Crossing of antenna cables should be done at 90° to minimise magnetic field coupling.

All outdoor installed connectors on the coaxial cables should be waterproof by design to protect against water penetration into the antenna cable.

## **2.4 Power source**

The AIS should be connected to an emergency power source.

## **2.5 Synchronization**

After installation, the AIS should be synchronised properly on UTC and that position information, if provided, should be correct and valid.

## **3 Bridge Arrangement**

### **3.1 Minimum Keyboard and Display**

The functionality of the Minimum Keyboard and Display (MKD) should be available to the mariner at the position from which the ship is normally operated. This can be by means of the AIS' internal MKD (integrated or remote) or through the equivalent functionality on a separate display system

### **3.2 Pilot plug**

A pilot input/output port is part of an AIS Class A station. A plug connected to this port should be installed on the bridge near the pilot's operating position so that a pilot can connect a Personal Pilot Unit (PPU).

The pilot plug should be configured as follows:

- AMP/Receptacle (Square Flanged (-1) or Free-Hanging (-2)), Shell size 11, 9-pin, Std. Sex 206486-1/2 or equivalent with the following terminations:
  - TX A is connected to Pin 1
  - TX B is connected to Pin 4
  - RX A is connected to Pin 5
  - RX B is connected to Pin 6
  - Shield is connected to Pin 9

### **3.3 Display system**

If there is navigational equipment capable of processing and displaying AIS information such as ECDIS, radar or an integrated system available on board the ship, the AIS Class A mobile system may be connected to that system via the AIS Presentation Interface (PI). The PI (input/output) should meet the requirements of IEC 61162-2.

The display system can also include the functionality of an MKD, see 3.1.

### **3.4 Installation of the BIIT (Built-in Integrity Test) function**

The AIS requires that an alarm output (relay) be connected to an audible alarm device or the ships alarm system, if available.

Alternatively, the BIIT alarm system may use the alarm messages output on the PI, provided its alarm system is AIS compatible.

## **4 Dynamic data input**

### **4.1 External Sensors**

The AIS has interfaces (configurable as IEC 61162-1 or 61162-2) for position, heading and rate of turn (ROT) sensors. In general, sensors installed in compliance with other carriage requirements of SOLAS Chapter V should be connected to the AIS.<sup>1</sup> The sensor information transmitted by AIS should be the same information being used for navigation of the ship. The interfaces should be configured as given in annex 3. Interfacing problems might occur if the existing sensors found on board do not have serial (IEC 61162) outputs.

### **4.2 Position, COG and SOG**

GNSS sensors normally have IEC 61162 outputs for position, COG and SOG suitable for directly interfacing the AIS. However, it is important to note that:

- The Geodetic Datum of the position data transmitted by the sensor is WGS 84 and that an IEC 61162 DTM sentence is configured.
- AIS is able to process two reference points for its antenna position, one for external and one for an internal sensor. If more than one external reference point is used, the appropriate information needs to be input to the AIS to adjust reference point information.

### **4.3 Heading**

A compass providing heading information is a mandatory sensor input to the AIS. A converter unit (e.g. stepper to NMEA) will be needed to connect AIS if the ship's compass does not provide an IEC 61162 output. Some ships of less than 500 gross tonnage may not carry a compass providing heading information.

### **4.4 Rate of Turn**

All ships may not carry a Rate-Of-Turn (ROT) Indicator according to resolution A.526(13). However, if a rate-of-turn indicator is available and it includes an IEC 61162 interface, it should be connected to the AIS.

If ROT information is not available from a ROT indicator, the direction of turn may (optionally) be derived from heading information through:

- The compass itself,
- An external converter unit (see paragraph 4.3),
- The AIS itself (see annex 1).

---

<sup>1</sup> Installation of the AIS does NOT establish a need to install additional sensors above carriage requirements.



#### 4.5 *Navigational Status*

A simple means should be provided for the operator to input the ship's navigational status (e.g. underway using engine, at anchor, not under command, restricted in ability to maneuver, etc) information into the AIS. The AIS may be connected to the ship's navigational status lights.

### 5 **Static Information**

The AIS standards require that certain static, voyage-related, and dynamic information be entered manually, normally by means of the MKD, or by means of IEC 61162 sentences "SSD" and "VSD" via the presentation interface if such provisions exist.

#### 5.1 *Entered at initial installation of AIS*

Information that should be entered at the initial installation of the AIS includes:

- Maritime Mobile Service Identity (MMSI) number
- IMO vessel number
- Radio call sign
- Name of ship
- Type of ship
- Dimension/reference for position of the electronic position fixing device (EPFD) antenna (see paragraph 5.2)

Access to **MMSI, IMO number** and other AIS controls (like power and channel settings) will be controlled, e.g. by password.

The **Call Sign, Name of Ship** and **Type of Ship** should be input to the AIS, either manually using the MKD or by means of IEC 61162 sentences "SSD" and "VSD" via the PI. Type of Ship information should be in accordance with the table given in annex 2 (Table 18 from Rec. ITU-R M.1371-1).

For example, a cargo ship not carrying dangerous goods, harmful substances, or marine pollutants; would use identifier "70". Pleasure craft would use identifier "37". Note that those ships whose type identifier begins with a "3" should use the fourth column of the table.

Depending on the vessel, cargo and/or the navigational conditions, this information may be voyage related and would therefore need to be changed before beginning or at some time during the voyage. This is defined by the "second digit" in the fourth column of the table.

#### 5.2 *Reference point of position*

The AIS stores one "external reference point" for the external GNSS antenna position and one "internal reference point" if an internal GNSS is to be used as fallback for position reporting. The locations of these reference points have to be set during installation using values A, B, C, D; as described in paragraph 5.3.

The external reference point may also be a calculated common reference position.

Additionally, the content of the Ship Static Data (“SSD”) sentence on the PI, including the “reference point for position” is being processed by the AIS, and the AIS’ memory for the “external reference point” is set in accordance with the content of this “SSD” (e.g. used by an INS).

### 5.3 Ship’s dimensions

Ship’s dimensions should be entered using the overall length and width of the ship indicated by the values A, B, C, and D in the following figure.

Ship’s dimensions (A+B and C+D) should be identical when entering internal and external reference points.

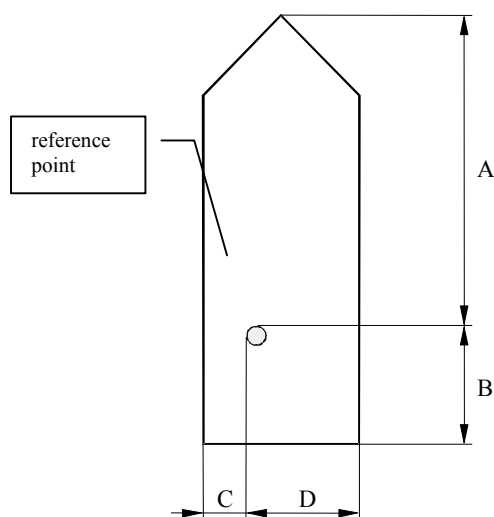

	Distance (m)
A	0 - 511 ; 511 = 511 m or greater
B	0 - 511 ; 511 = 511 m or greater
C	0 - 63 ; 63 = 63 m or greater
D	0 - 63 ; 63 = 63 m or greater

The dimension A should be in the direction of the transmitted heading information (bow)

*Reference point of reported position not available, but dimensions of ship are available: A = C = 0 and B ≠ 0 and D ≠ 0.*

*Neither reference point of reported position nor dimensions of ship available: A = B = C = D = 0 (=default)*

*For use in the message table, A = most significant field, D = least significant field*

In the rare case of an EPFD antenna installed in the portside corner of a rectangular bow, the values A and C would be zero. Should this be the case, one of these values should be set to 1 in order to avoid misinterpretation as “not available“ because A=C=0 is used for that purpose.

## 6 Long-range function

The AIS’ long-range function needs a compatible long-range communication system (e.g. Inmarsat-C or MF/HF radio as part of the GMDSS).

If this is available, a connection between that communication system and the Class A mobile unit can be made. This connection is needed to activate the LR function of AIS. Its input/output port should meet the requirement of IEC 61162-2.

Annex 1

**RATE OF TURN**

The AIS provides the Rate of Turn (ROT) information to other ships in order to early detect ships manoeuvres. There are two possible parameters indicating turning of a ship derived from two different sensors (see Figure 3: ROT sensor input):

- the heading from a GYRO or THD and
- the rotation rate itself from a Rate of Turn-indicator.

If a Rate of Turn Indicator according to resolution A.526(13) is connected, the AIS should use this information to broadcast both direction and value of turn on the VDL.

If valid ROT or HDG data is available from other external sources (Gyro, INS,...), the AIS should use this information to broadcast the direction of turn on the VDL, if greater than 5° in 30 s (might also be implemented as 2.5° in 15 s by configuration); the AIS may also derive ROT information from HDG internally for that purpose.

**If no ROT information is available, the AIS should transmit default values indicating “not available”. ROT data should not be derived from COG information.**

**If a ship is not required to carry Turn-Indicator or if external sensor fails, the AIS should react according to following priorities:**

**ROT sensor fallback conditions**

Priority	Affected data in msg 1, 2, 3 ⇒	contents of ROT field
	Position Sensor status	
1.	Rate of Turn Indicator in use <sup>1</sup>	0..+ 126 = turning right at up to 708° per minute or higher; 0..- 126 = turning left at up to 708° per minute or higher  Values between 0 and 708°/min should be coded by $ROT_{AIS} = 4.733 \text{ SQRT}(ROT_{sensor})$ degrees/min where $ROT_{sensor}$ is the Rate of Turn as input by the external Rate of Turn Indicator (TI).  Values of 709° per minute and above should be limited to 708° per min.
2.	other ROT source in use <sup>2</sup>	+ 127 = turning right at more than 5°/30s (No TI available) 0 no turn  - 127 = turning Left at more than 5°/30s (No TI available)
3.	no valid ROT information available	-128 (80 hex) indicates no turn information available (default)

<sup>1</sup> Rate of Turn Indicator according to resolution A.526(13); determined by talker ID

<sup>2</sup> i.e. based on HDG information

**Rate of Turn sensor input overview**

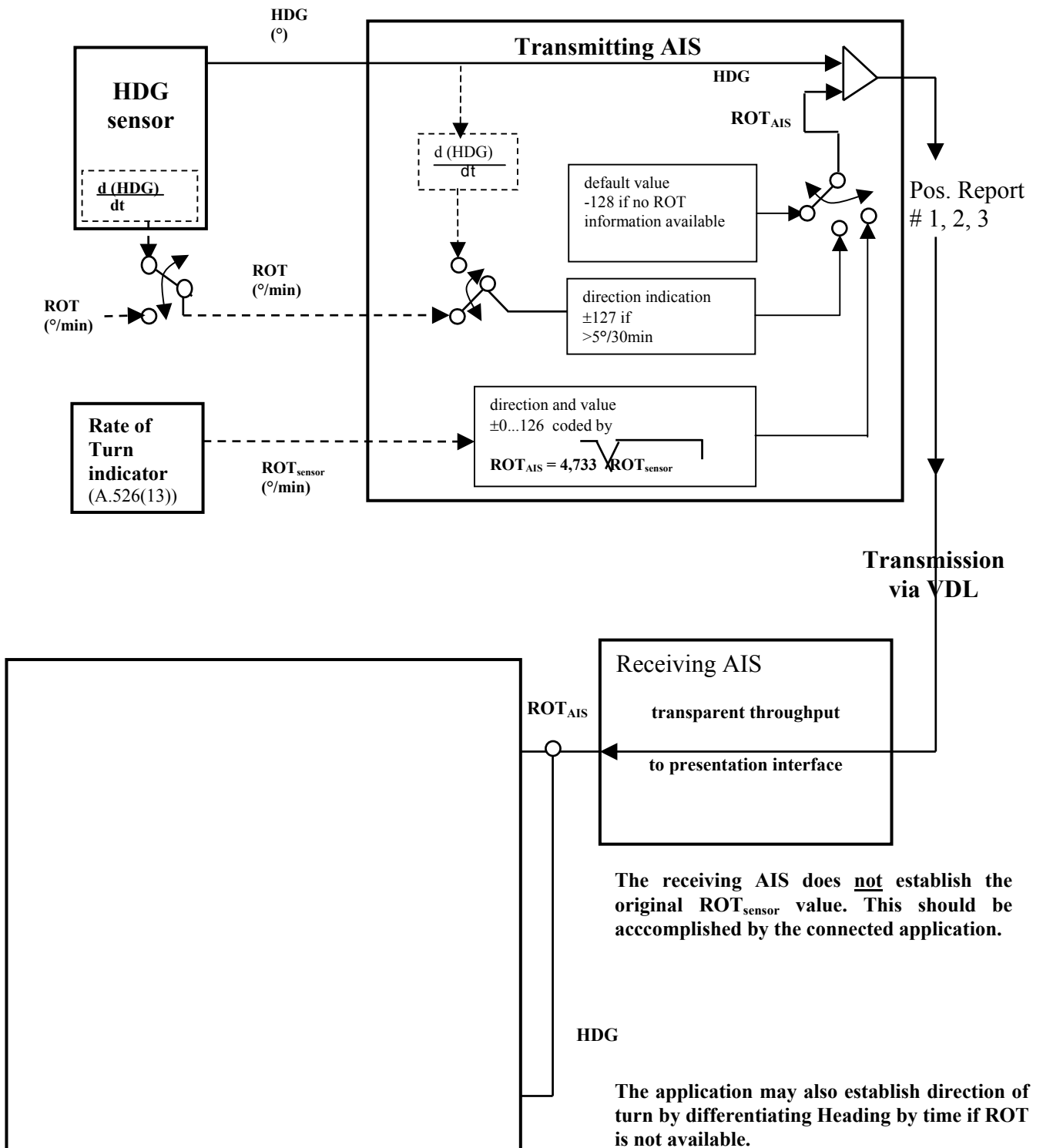

Annex 2

**TYPE OF SHIP TABLE**

Identifiers to be used by ships to report their type			
Identifier No.	Special craft		
50	Pilot vessel		
51	Search and rescue vessels		
52	Tugs		
53	Port tenders		
54	Vessels with anti-pollution facilities or equipment		
55	Law enforcement vessels		
56	Spare – for assignments to local vessels		
57	Spare – for assignments to local vessels		
58	Medical transports (as defined in the 1949 Geneva Convention and Additional Protocols)		
59	Ships according to Resolution No 18 (Mob-83)		
Other ships			
First digit (*)	Second digit (*)	First digit (*)	Second digit (*)
1 - reserved for future use	0 – All ships of this type	-	0 – Fishing
	1 – Carrying DG, HS, or MP IMO hazard or pollutant category A	-	1 – Towing
3 - see right column	2 – Carrying DG, HS, or MP IMO hazard or pollutant category B		2 – Towing and length of the tow exceeds 200 m or breadth exceeds 25 m
	3 – Carrying DG, HS, or MP IMO hazard or pollutant category C	-	3 – Engaged in dredging or underwater operations
5 – see above	4 – Carrying DG, HS, or MP IMO hazard or pollutant category D	-	4 – Engaged in diving operations
	5 – reserved for future use	-	5 – Engaged in military operations
	6 – reserved for future use	-	6 – Sailing
	7 – reserved for future use	-	7 – Pleasure Craft
	8 – reserved for future use	-	8 – reserved for future use
	9 – No additional information	-	9 – reserved for future use

DG: Dangerous Goods.  
HS: Harmful Substances.  
MP: Marine Pollutants.

(\* ) **NOTE** – The identifier should be constructed by selecting the appropriate first and second digits.

Annex 3

**RECOMMENDED IEC 61162 SENTENCES**

To connect external sensors it is recommended to configure the following sentences as indicated below.

**Preferred IEC 61162-1 Sensor Sentences**

<b>Data</b>	<b>IEC 61162-1 Sentence formatters</b>	
	<b>preferred</b>	<b>optional</b>
Reference datum	DTM	
Positioning system: Time of position Latitude / Longitude Position accuracy	GNS GLL	GGA , RMC
Speed Over Ground (SOG)	VBW	VTG, OSD, RMC
Course Over Ground (COG)	RMC	VTG, OSD
Heading	HDT	OSD
RAIM indicator	GBS	
Rate Of Turn (ROT)	ROT	

