

# Crew Fatality On Forecastle during Unmooring Operation

## 1. The Incident

- 1.1 On 26 February 2006, while a Hong Kong registered ship was departing from a berth in Qingdao in China, the Chief Officer who was in charge of the unmooring operation on the forecastle was hit by a parted forward spring rope. He was sent to the hospital and later certified dead.

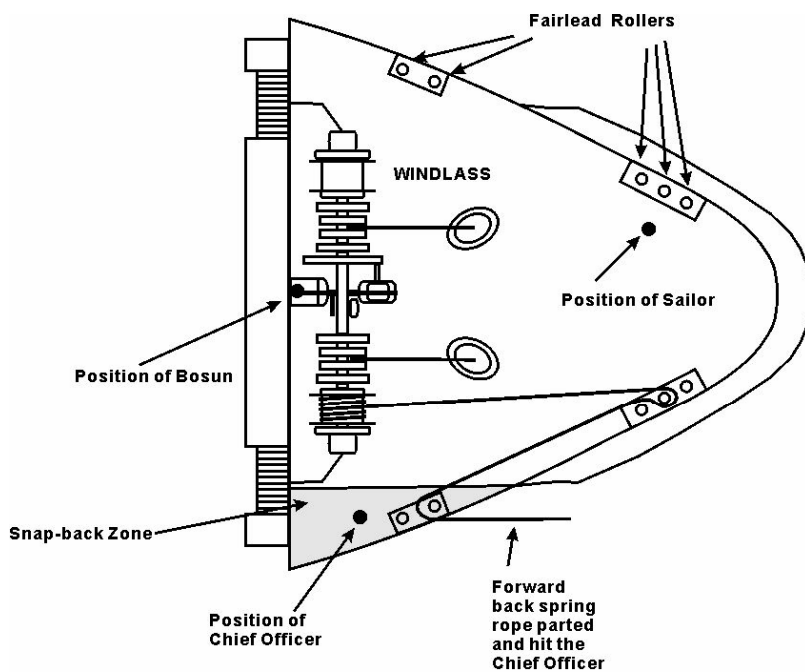

Diagram showing the positions of the Chief Officer, Bosun and Sailor

## 2. Lessons

- 2.1 Crew members should be aware of the hazards of working on forecastle and poop deck during mooring/unmooring operations. They should stay alert to the possible hazards associated with mooring ropes under tension and keep well clear of the snap-back zone.