



Ref. T5/1.01

MEPC.1/Circ.681
17 August 2009

INTERIM GUIDELINES ON THE METHOD OF CALCULATION OF THE ENERGY EFFICIENCY DESIGN INDEX FOR NEW SHIPS

1 The Marine Environment Protection Committee, at its fifty-ninth session (13 to 17 July 2009), recognized the need to develop an energy efficiency design index for new ships in order to stimulate innovation and technical development of all elements influencing the energy efficiency of a ship from its design phase. The Committee, being mindful that the applicability of the EEDI formula to all categories of ships and the feasibility and applicability of the technical parameters (i.e. $f_{eff(i)}$ and f_w) in the EEDI formula need to be further refined to improve the method of calculation of the EEDI; agreed to circulate the Interim Guidelines on the method of calculation of the energy efficiency design index for new ships, as set out in the annex.

2 Member Governments and observer organizations are invited to use the interim guidelines, for the purpose of test and trials on a voluntary basis:

- .1 for ships with conventional propulsion systems (main engine mechanical drive);
and
- .2 to the extent possible, for ships with non-conventional propulsion systems (e.g., diesel-electric propulsion, turbine propulsion or hybrid propulsion systems).

3 Member Governments and observer organizations are also invited to provide the outcome and experiences in applying the interim Guidelines to future sessions of the Committee for further improvement of the method of calculation of the EEDI for new ships.

ANNEX

**INTERIM GUIDELINES ON THE METHOD OF CALCULATION OF
THE ENERGY EFFICIENCY DESIGN INDEX FOR NEW SHIPS**

1 Definitions

For the purpose of these Guidelines, the following definitions should apply:

.1	Passenger ship	a ship which carries more than 12 passengers as defined in SOLAS chapter 1, regulation 2
.2	Dry cargo carrier	a ship which is constructed generally with single deck, topside tanks and hopper tanks in cargo spaces, and it is intended primarily to carry dry cargo in bulk, and includes such types as ore carriers and combination carriers, as defined in SOLAS chapter IX, regulation 1
.3	Gas tanker	a gas carrier as defined in SOLAS chapter II-1, regulation 3
.4	Tanker	an oil tanker as defined in MARPOL Annex I, regulation 1 or chemical tanker and a NLS tanker as defined in MARPOL Annex II, regulation 1
.5	Containership	a ship designed exclusively for the carriage of containers in holds and on deck
.6	Ro-ro cargo ship: Vehicle carrier	A multi deck ro-ro cargo ship designed for the carriage of empty cars and trucks
.7	Ro-ro cargo ship: Volume carrier	A ro-ro cargo ship, with a deadweight per lanemetre less than 4* tons/m, designed for the carriage of cargo transportation units
.8	Ro-ro cargo ship: Weight carrier	A ro-ro cargo ship, with a deadweight per lanemetre of 4* tons/m or above, designed for the carriage of cargo transportation units
.9	General cargo ship	A ship with a multi-deck or single-deck hull designed primarily for the carriage of general cargo
.10	Ro-ro passenger ship	A passenger ship as defined in SOLAS chapter II-1, Part A, regulation 2.23

Ships falling within more than one of the ship types should be considered as being the ship type with the lower baseline.

* The value should be further investigated during the period of voluntary use of the EEDI.

2 Energy Efficiency Design Index (EEDI)

The attained new ship Energy Efficiency Design Index (EEDI) is a measure of ships CO₂ efficiency and calculated by the following formula:

$$\frac{\left(\prod_{j=1}^M f_j \right) \left(\sum_{i=1}^{nME} P_{ME(i)} \cdot C_{FME(i)} \cdot SFC_{ME(i)} \right) + (P_{AE} \cdot C_{FAE} \cdot SFC_{AE}^*) + \left(\left(\prod_{j=1}^M f_j \cdot \sum_{i=1}^{nPTI} P_{PTI(i)} - \sum_{i=1}^{neff} f_{eff(i)} \cdot P_{AEeff(i)} \right) C_{FAE} \cdot SFC_{AE} \right) - \left(\sum_{i=1}^{neff} f_{eff(i)} \cdot P_{eff(i)} \cdot C_{FME} \cdot SFC_{ME} \right)}{f_i \cdot Capacity \cdot V_{ref} \cdot f_w}$$

* If part of the Normal Maximum Sea Load is provided by shaft generators, SFC_{ME} may – for that part of the power – be used instead of SFC_{AE}

Note: This formula may not be able to apply to diesel-electric propulsion, turbine propulsion or hybrid propulsion system.

Where:

1. C_F is a non-dimensional conversion factor between fuel consumption measured in g and CO₂ emission also measured in g based on carbon content. The subscripts ME_i and AE_i refer to the main and auxiliary engine(s) respectively. C_F corresponds to the fuel used when determining SFC listed in the applicable EIAPP Certificate. The value of C_F is as follows:

Type of fuel	Reference	Carbon content	C_F (t-CO ₂ /t-Fuel)
1. Diesel/Gas Oil	ISO 8217 Grades DMX through DMC	0.875	3.206000
2. Light Fuel Oil (LFO)	ISO 8217 Grades RMA through RMD	0.86	3.151040
3. Heavy Fuel Oil (HFO)	ISO 8217 Grades RME through RMK	0.85	3.114400
4. Liquefied Petroleum Gas (LPG)	Propane	0.819	3.000000
	Butane	0.827	3.030000
5. Liquefied Natural Gas (LNG)		0.75	2.750000

2. V_{ref} is the ship speed, measured in nautical miles per hour (knot), on deep water in the maximum design load condition (*Capacity*) as defined in paragraph 3 at the shaft power of the engine(s) as defined in paragraph 5 and assuming the weather is calm with no wind and no waves. The maximum design load condition shall be defined by the deepest draught with its associated trim, at which the ship is allowed to operate. This condition is obtained from the stability booklet approved by the Administration.
3. *Capacity* is defined as follows:
 - 3.1 For dry cargo carriers, tankers, gas tankers, containerships, ro-ro cargo and general cargo ships, deadweight should be used as *Capacity*.

- .3.2 For passenger ships and ro-ro passenger ships, gross tonnage in accordance with the International Convention of Tonnage Measurement of Ships 1969, Annex I, regulation 3 should be used as *Capacity*.
- .3.3 For containerships, the capacity parameter should be established at 65% of the deadweight.
- .4 *Deadweight* means the difference in tonnes between the displacement of a ship in water of relative density of 1,025 kg/m³ at the deepest operational draught and the lightweight of the ship.
- .5 *P* is the power of the main and auxiliary engines, measured in kW. The subscripts *ME* and *AE* refer to the main and auxiliary engine(s), respectively. The summation on *i* is for all engines with the number of engines (^{*n*}*ME*). (See the diagram in the Appendix.)
- .5.1 $P_{ME(i)}$ is 75% of the rated installed power (MCR) for each main engine (*i*) after having deducted any installed shaft generator(s):

$$P_{ME(i)} = 0.75 \times (MCR_{MEi} - P_{PTOi})$$

The following figure gives guidance for determination of $P_{ME(i)}$:

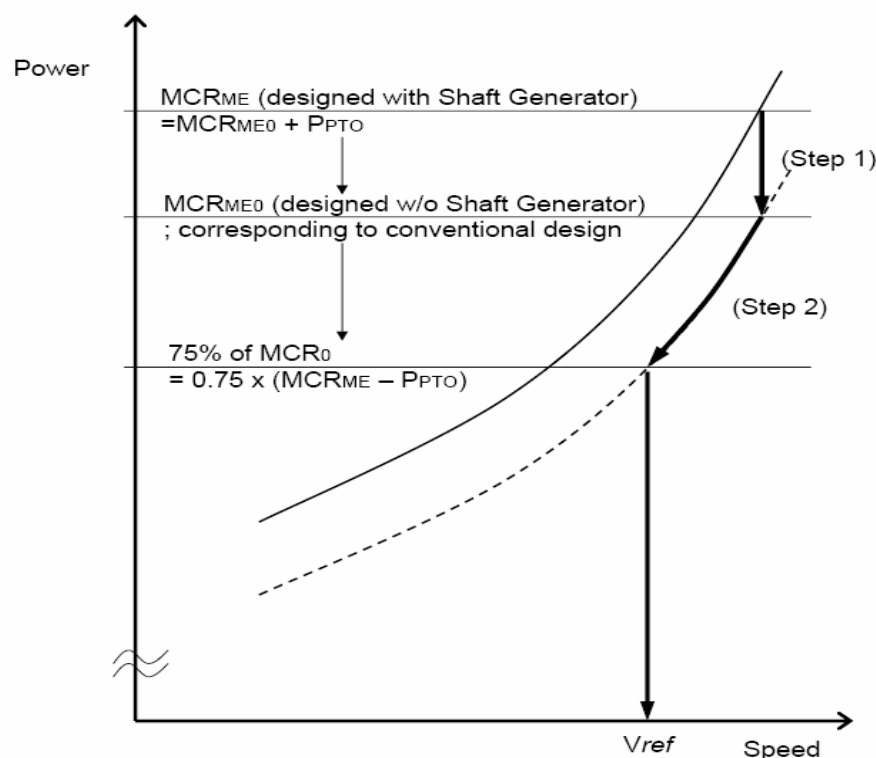

- .5.2 $P_{PTO(i)}$ is 75% output of each shaft generator installed divided by the relevant efficiency of that shaft generator.
- .5.3 $P_{PTI(i)}$ is 75% of the rated power consumption of each shaft motor divided by the weighted averaged efficiency of the generator(s).

In case of combined PTI/PTO, the normal operational mode at sea will determine which of these to be used in the calculation.

Note: The shaft motor's chain efficiency may be taken into consideration to account for the energy losses in the equipment from the switchboard to the shaft motor, if the chain efficiency of the shaft motor is given in a verified document.

- .5.4 $P_{eff(i)}$ is 75% of the main engine power reduction due to innovative mechanical energy efficient technology.

Mechanical recovered waste energy directly coupled to shafts need not be measured.

- .5.5 $P_{AEeff(i)}$ is the auxiliary power reduction due to innovative electrical energy efficient technology measured at $P_{ME(i)}$.

- .5.6 P_{AE} is the required auxiliary engine power to supply normal maximum sea load including necessary power for propulsion machinery/systems and accommodation, e.g., main engine pumps, navigational systems and equipment and living on board, but excluding the power not for propulsion machinery/systems, e.g., thrusters, cargo pumps, cargo gear, ballast pumps, maintaining cargo, e.g., reefers and cargo hold fans, in the condition where the ship engaged in voyage at the speed (V_{ref}) under the design loading condition of *Capacity*.

- .1 For cargo ships with a main engine power of 10000 kW or above, P_{AE} is defined as:

$$P_{AE(MCRME>10000KW)} = \left(0.025 \times \sum_{i=1}^{nME} MCR_{MEi} \right) + 250$$

- .2 For cargo ships with a main engine power below 10000 kW, P_{AE} is defined as:

$$P_{AE(MCRME<10000KW)} = 0.05 \times \sum_{i=1}^{nME} MCR_{MEi}$$

- .3 For ship types where the P_{AE} value calculated by .1 or .2 above is significantly different from the total power used at normal seagoing, e.g., in cases of passenger ships, the P_{AE} value should be estimated by the consumed electric power (excluding propulsion) in conditions when the ship is engaged in a voyage at reference speed (V_{ref}) as given in the electric power table*, divided by the weighted average efficiency of the generator(s).

* **Note:** The electric power table is often verified and approved by the Administration/Recognized Organization as documentation relating to SOLAS chapter II-1, Part D, regulation 40.1.1. The electric power table shows a generator load summary in kW and lists generators in service at different conditions of ship operation, e.g., "normal seagoing at full passenger load", where the ambient conditions are as follows: outside temperature is 35°C, the relative humidity is 85% and the seawater temperature is 32°C.

- .6 V_{ref} , Capacity and P should be consistent with each other.
- .7 SFC is the certified specific fuel consumption, measured in g/kWh, of the engines. The subscripts $ME(i)$ and $AE(i)$ refer to the main and auxiliary engine(s), respectively. For engines certified to the E2 or E3 duty cycles of the NO_x Technical Code 2008, the engine Specific Fuel Consumption ($SFC_{ME(i)}$) is that recorded on the EIAPP Certificate(s) at the engine(s) 75% of MCR power or torque rating. For engines certified to the D2 or C1 duty cycles of the NO_x Technical Code 2008, the engine Specific Fuel Consumption ($SFC_{AE(i)}$) is that recorded on the EIAPP Certificate(s) at the engine(s) 50% of MCR power or torque rating.

For ships where the P_{AE} value calculated by 2.5.6.1 and 2.5.6.2 is significantly different from the total power used at normal seagoing, e.g., conventional passenger ships, the Specific Fuel Consumption (SFC_{AE}) of the auxiliary generators is that recorded in the EIAPP Certificate(s) for the engine(s) at 75% of P_{AE} MCR power of its torque rating.

SFC_{AE} is the weighted average among $SFC_{AE(i)}$ of the respective engines i .

For those engines which do not have an EIAPP Certificate because its power is below 130 kW, the SFC specified by the manufacturer and endorsed by a competent authority should be used.

- .8 f_j is a correction factor to account for ship specific design elements.

The f_j for ice-classed ships is determined by the standard f_j in Table 1.

Table 1

Correction factor for power f_j for ice-classed ships

For further information on approximate correspondence between ice classes, see HELCOM Recommendation 25/7*

Ship type	f_j	Limits depending on the ice class			
		IC	IB	IA	IA Super
Tanker	$\frac{0.516L_{PP}^{1.87}}{\sum_{i=1}^{nME} P_{iME}}$	$\left\{ \begin{array}{l} \text{max } 1.0 \\ \text{min } 0.72L_{PP}^{0.06} \end{array} \right\}$	$\left\{ \begin{array}{l} \text{max } 1.0 \\ \text{min } 0.61L_{PP}^{0.08} \end{array} \right\}$	$\left\{ \begin{array}{l} \text{max } 1.0 \\ \text{min } 0.50L_{PP}^{0.10} \end{array} \right\}$	$\left\{ \begin{array}{l} \text{max } 1.0 \\ \text{min } 0.40L_{PP}^{0.12} \end{array} \right\}$
Dry cargo carrier	$\frac{2.150L_{PP}^{1.58}}{\sum_{i=1}^{nME} P_{iME}}$	$\left\{ \begin{array}{l} \text{max } 1.0 \\ \text{min } 0.89L_{PP}^{0.02} \end{array} \right\}$	$\left\{ \begin{array}{l} \text{max } 1.0 \\ \text{min } 0.78L_{PP}^{0.04} \end{array} \right\}$	$\left\{ \begin{array}{l} \text{max } 1.0 \\ \text{min } 0.68L_{PP}^{0.06} \end{array} \right\}$	$\left\{ \begin{array}{l} \text{max } 1.0 \\ \text{min } 0.58L_{PP}^{0.08} \end{array} \right\}$
General cargo ship	$\frac{0.0450 \cdot L_{PP}^{2.37}}{\sum_{i=1}^{nME} P_{iME}}$	$\left\{ \begin{array}{l} \text{max } 1.0 \\ \text{min } 0.85L_{PP}^{0.03} \end{array} \right\}$	$\left\{ \begin{array}{l} \text{max } 1.0 \\ \text{min } 0.70L_{PP}^{0.06} \end{array} \right\}$	$\left\{ \begin{array}{l} \text{max } 1.0 \\ \text{min } 0.54L_{PP}^{0.10} \end{array} \right\}$	$\left\{ \begin{array}{l} \text{max } 1.0 \\ \text{min } 0.39L_{PP}^{0.15} \end{array} \right\}$

For other ship types, f_j should be taken as 1.0.

* HELCOM Recommendation 25/7 may be found at <http://www.helcom.fi>.

- .9 f_w is a non-dimensional coefficient indicating the decrease of speed in representative sea conditions of wave height, wave frequency and wind speed (e.g., Beaufort Scale 6), and should be determined as follows:
- .9.1 It can be determined by conducting the ship-specific simulation of its performance at representative sea conditions. The simulation methodology should be prescribed in the Guidelines developed by the Organization and the method and outcome for an individual ship shall be verified by the Administration or an organization recognized by the Administration.
- .9.2 In case that the simulation is not conducted, f_w value should be taken from the “Standard f_w ” table/curve. A “Standard f_w ” table/curve, which is to be contained in the Guidelines, is given by ship type (the same ship as the “baseline” below), and expressed in a function of the parameter of *Capacity* (e.g., DWT). The “Standard f_w ” table/curve is to be determined by conservative approach, i.e. based on data of actual speed reduction of as many existing ships as possible under representative sea conditions.
- .9.3 f_w should be taken as one (1.0) until the Guidelines for the ship-specific simulation (paragraph .9.1) or f_w table/curve (paragraph .9.2) becomes available.
- .10 $f_{eff(i)}$ is the availability factor of each innovative energy efficiency technology. $f_{eff(i)}$ for waste energy recovery system should be one (1.0).
- .11 f_i is the capacity factor for any technical/regulatory limitation on capacity, and can be assumed one (1.0) if no necessity of the factor is granted.

f_i for ice-classed ships is determined by the standard f_i in Table 2.

Table 2

Capacity correction factor f_i for ice-classed ships

For further information on approximate correspondence between ice classes,
see HELCOM Recommendation 25/7*

Ship type	f_i	Limits depending on the ice class			
		IC	IB	IA	IA Super
Tanker	$\frac{0.00115L_{PP}^{3.36}}{\text{capacity}}$	$\begin{cases} \max 1.31L_{PP}^{-0.05} \\ \min 1.0 \end{cases}$	$\begin{cases} \max 1.54L_{PP}^{-0.07} \\ \min 1.0 \end{cases}$	$\begin{cases} \max 1.80L_{PP}^{-0.09} \\ \min 1.0 \end{cases}$	$\begin{cases} \max 2.10L_{PP}^{-0.11} \\ \min 1.0 \end{cases}$
Dry cargo carrier	$\frac{0,000665 \cdot L_{PP}^{3.44}}{\text{capacity}}$	$\begin{cases} \max 1.31L_{PP}^{-0.05} \\ \min 1.0 \end{cases}$	$\begin{cases} \max 1.54L_{PP}^{-0.07} \\ \min 1.0 \end{cases}$	$\begin{cases} \max 1.80L_{PP}^{-0.09} \\ \min 1.0 \end{cases}$	$\begin{cases} \max 2.10L_{PP}^{-0.11} \\ \min 1.0 \end{cases}$
General cargo ship	$\frac{0,000676 \cdot L_{PP}^{3.44}}{\text{capacity}}$	1.0	$\begin{cases} \max 1.08 \\ \min 1.0 \end{cases}$	$\begin{cases} \max 1.12 \\ \min 1.0 \end{cases}$	$\begin{cases} \max 1.25 \\ \min 1.0 \end{cases}$
Containership	$\frac{0.1749 \cdot L_{PP}^{2.29}}{\text{capacity}}$	1.0	$\begin{cases} \max 1.25L_{PP}^{-0.04} \\ \min 1.0 \end{cases}$	$\begin{cases} \max 1.60L_{PP}^{-0.08} \\ \min 1.0 \end{cases}$	$\begin{cases} \max 2.10L_{PP}^{-0.12} \\ \min 1.0 \end{cases}$
Gas tanker	$\frac{0.1749 \cdot L_{PP}^{2.33}}{\text{capacity}}$	$\begin{cases} \max 1.25L_{PP}^{-0.04} \\ \min 1.0 \end{cases}$	$\begin{cases} \max 1.60L_{PP}^{-0.08} \\ \min 1.0 \end{cases}$	$\begin{cases} \max 2.10L_{PP}^{-0.12} \\ \min 1.0 \end{cases}$	1.0

For other ship types, f_i should be taken as 1.0.

- .12 *Length between perpendiculars, L_{pp}* means 96 per cent of the total length on a waterline at 85 per cent of the least moulded depth measured from the top of the keel, or the length from the foreside of the stem to the axis of the rudder stock on that waterline, if that were greater. In ships designed with a rake of keel the waterline on which this length is measured shall be parallel to the designed waterline. The length between perpendiculars (L_{pp}) shall be measured in metres.

* * *

* HELCOM Recommendation 25/7 may be found at <http://www.helcom.fi>.

Appendix

A generic and simplified marine power plant

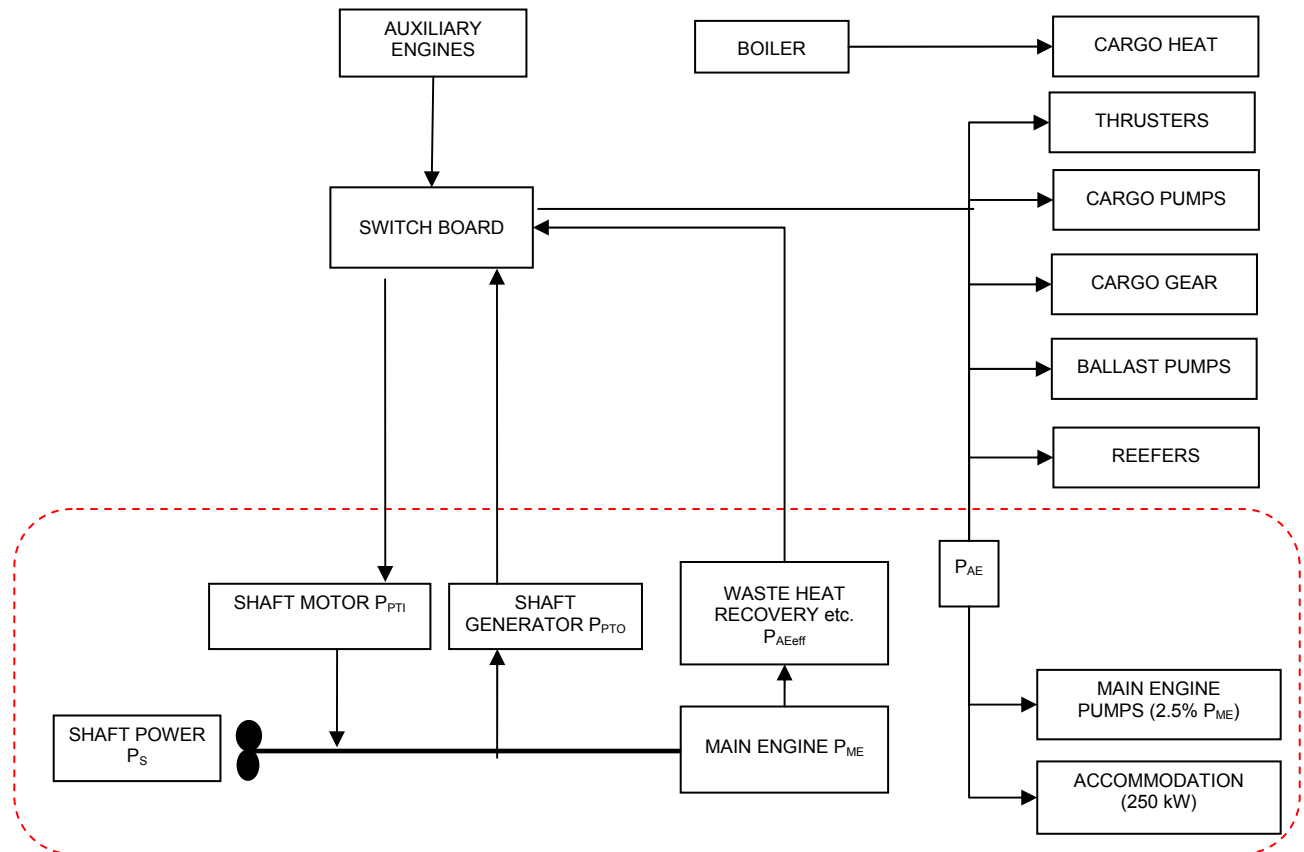

Note 1: Mechanical recovered waste energy directly coupled to shafts need not be measured.

Note 2: In case of combined PTI/PTO, the normal operational mode at sea will determine which of these to be used in the calculation.